

Axioplan Universal Microscope

Transmitted light and
incident-light fluorescence

Operating instructions

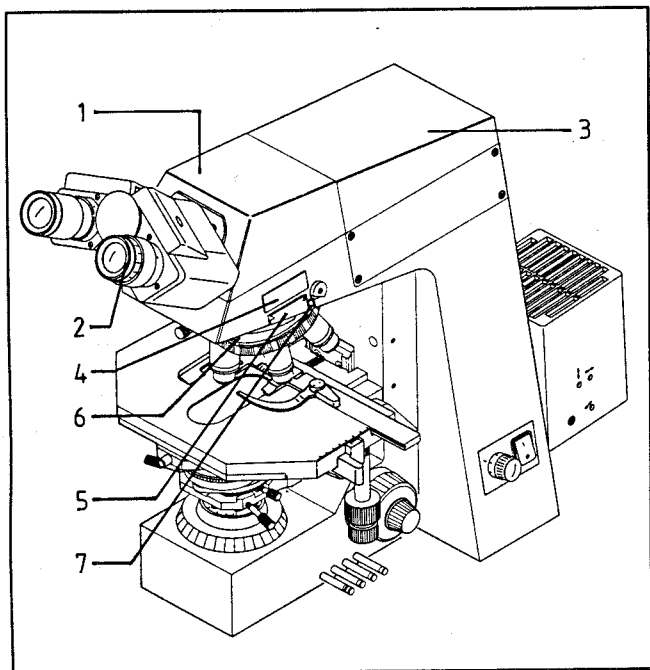

Tube

- 1 Binocular tube
- 2 Eyepiece

Stand head and stand head carrier with incident-light system FI

- 3 Tube panel
- 4 Slot for analyzer and Bertrand lens slider
- 5 Slot for Optovar slider and reflector slider
- 6 Slot for auxiliary objects
- 7 Slot for reflected-light polarizer
- 8 Incident-light system FI (for incident-light fluorescence only)

Nosepiece, objectives

- 9 Nosepiece
- 10 Objectives

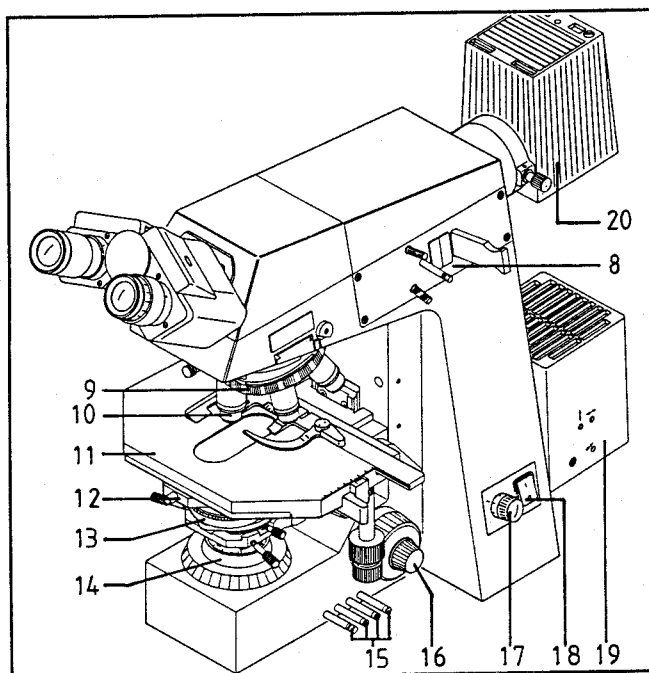

Stage components

- 11 Specimen stage
- 12 Stage carrier with condenser carrier
- 13 Condenser

Stand base

- 14 Luminous field diaphragm
- 15 Filter magazine
- 16 Coaxial coarse/fine focusing control

Lamp power supply and illuminators

- 17 Potentiometer for Hal illuminator
- 18 Power switch and signal lamp
- 19 Transmitted-light illuminator
- 20 Incident-light fluorescence illuminator

	Page
Microscope adjustment in brief (Practical microscopy with the ready instrument)	5
<hr/>	
Description of instrument (Components and operating controls of the ready instrument)	
1.0 Lamp power supply	6
2.0 Hal illuminator	7
3.0 Stand base	8
4.0 Specimen stage	9
5.0 Condensers	10
6.0 Image-forming components (objectives, nosepiece, eyepieces, magnification changer, Bertrand lens slider, DIC accessories, tubes)	14
7.0 Fluorescence equipment	18
<hr/>	
Fluorescence microscopy	19
<hr/>	
Phase contrast	21
<hr/>	
Darkfield illumination	22
<hr/>	
Differential interference contrast (DIC)	24
<hr/>	
Exchange of instrument components or parts	
Stage	25
Tube	25
Intermediate tubes	26
Condenser	27
Phase stops and/or DIC prisms in condenser turret	28
Fluorescence reflector	30
<hr/>	
Spare part ordering specifications	31
<hr/>	
Technical data	31
<hr/>	

Special notes :

- * The 6- to 10-digit numbers, e.g. 45 14 04, are ordering numbers of instruments or instrument components.
- * Changes and/or repairs of the instruments should be carried out only by the manufacturer or by persons he has expressly authorized to do so.
- * Specifications subject to change.
- * **CAUTION:** Do not operate the instruments in explosion-risk areas.

1

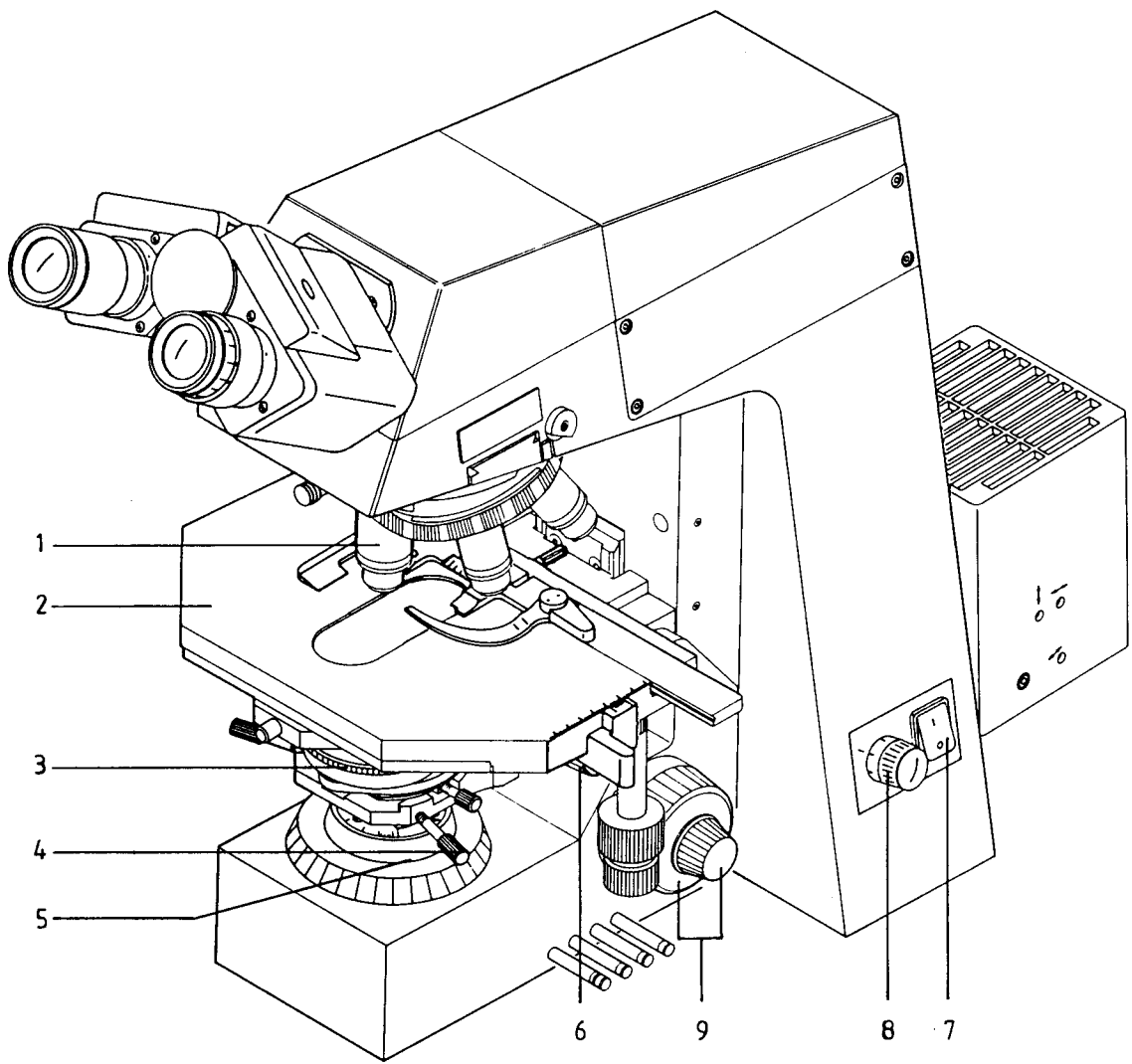

Note: Numbers like 1.1 refer to the description of the instrument starting on page 6.

- Check voltage on red display window (instrument back) and line voltage for coincidence. Plug in microscope power cable, select lower (or only) illuminator, switch on with (7) and set potentiometer (8) to 3-4 V.
- Load a high-contrast specimen on stage (smaller, thin cover glass face up!).
- Turn in 10x objective (yellow ring) (1) on nosepiece, check 0-positions on the eyepiece scale. With (6) move condenser up to the specimen carrier (front lens not swung out).
- Set index of condenser turret to H (brightfield) and close the diaphragm about half at (3).

You should now see light spots (the exit pupils) behind the eyepieces. With a binocular phototube all the light is directed to the binocular tubes if the pushrod is slid in all the way. When you look into the tube you will see a bright circle (the eyepiece stop) with each eye. Setting the two eyepiece tubes to your PD will merge the two circles into one.

Further steps of Köhler illumination adjustment:

- Focus the specimen with coarse/fine focusing control (9). (If your eyes have different powers and for work without eyeglasses - 6.6).
- Close luminous field diaphragm (5) moderately; it will become unsharp (A).
- Focus the diaphragm image by lowering the condenser slightly with (6) (B).
- Move the diaphragm image to the center of the field of view with screws (4) (C).
- Open luminous field diaphragm (5) until it just disappears from the field of view (D).

Readout of the diameter of the luminous field diaphragm and/or its reproducible setting are made with the white index mark on the knurled ring and the white scale (5).

The contrast is adjusted with condenser diaphragm (3), depending on the specimen. The setting of the aperture diaphragm is displayed on the condenser scale.

- If you are not certain how far to stop down: approx. 2/3 of the rear element of the objective (visible at the tube bottom without eyepiece in the tube) should be illuminated if a specimen is of moderate contrast (E).

Field of view and objective aperture change, of course, with each objective exchange, so that the last-mentioned steps must be repeated.

As soon as a low-power objective images more than the condenser can illuminate, the condenser front lens must be swung out, either automatically by lowering the condenser, or with a lever. The procedure is described starting on page 10.

2

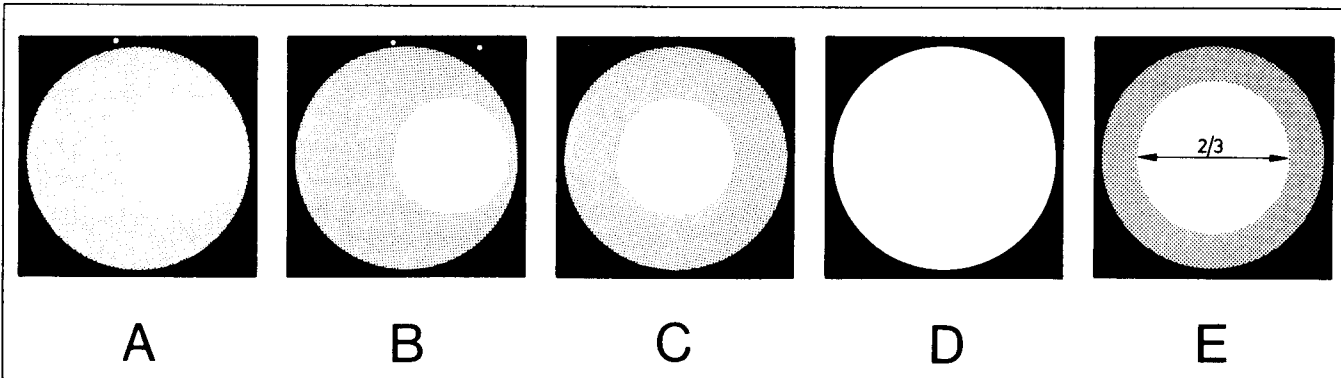

Special note:

Almost all screws you need are SW 3.0mm or SW 1.5mm Allen screws for which the tools with the red handles are supplied.

3

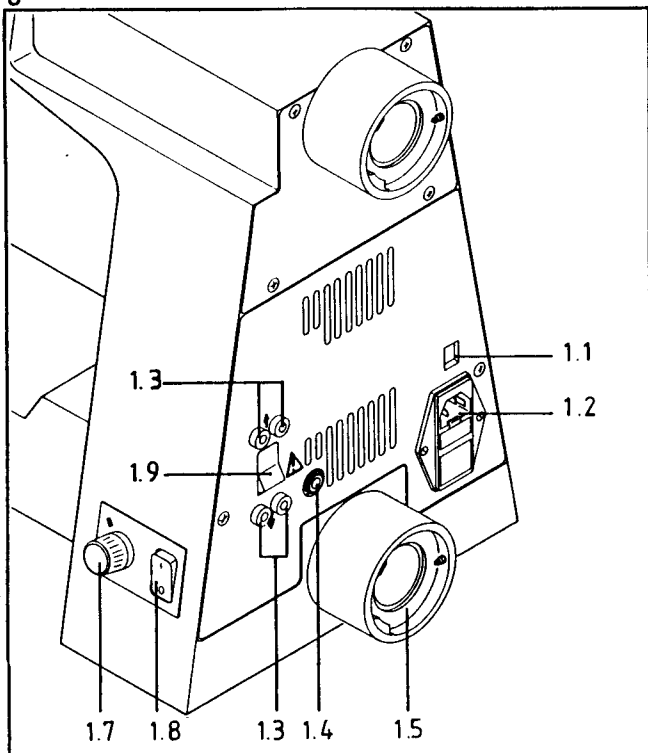
**1.0 Lamp power supply**

The power supply for the Hal illuminator is integrated in the Axioplan stand (45 18 10) (technical data see page 31).

1.1 Window displaying the adjusted instrument voltage, either 230V for 220 . . . 240V AC or 115V for 110. . . 120V AC.

If the local line voltage does not comply with the adjusted voltage, switch off the instrument and pull the power cable, then turn the switch vertically using a screwdriver and provide suitable fuses (see 1.2).

The highly stabilized power supply supplies DC voltage and is suitable for high-performance photometry (unmodulated light).

1.2 Power plug and, underneath, an insert with 2 fuses. If necessary, pull out the insert using a screwdriver and exchange the fuses (see page 31).



Connect only Hal lamp housing (44 72 17) with 12V 100W lamp (38 00 79-9540) (page 7) to sockets 1.3. Arrow up for reflected light, arrow down for transmitted light.

1.4 Socket for a control line to switch the lamp to 3200 K (color temperature for color photography), independent of the setting of potentiometer 1.7.

1.5 Port for transmitted-light illuminator.

A tube with heat-reflecting filter and diffusing screen for homogeneous illumination is integrated. The tube can be easily removed temporarily, to observe lamp coil and reflector image in the pupil for lamp centration.

1.6 Port for reflected-light illuminator with filter holder for 42mm dia. heat-reflecting filter.

1.7 Potentiometer to set the lamp voltage to 3 . . . 12V. The adjusted voltage is displayed and can be read off using the index.

Should the 12V 100W halogen lamp cause trouble during operation, it is automatically switched off electronically. Set to lowest value and switch off the lamp using toggle switch 1.8. Switch on again and select the desired lamp voltage.

1.8 Power switch with integrated signal lamp.

1.9 Toggle switch to change between reflected and transmitted-light illumination according to the arrows. The lamp will light a few seconds after switch-over.

2.0 Illuminator Hal

The standard equipment includes Hal lamp housing (44 72 17-9901) with reflector, collector, heat-reflecting filter and mount, and a 12V 100W halogen lamp (38 00 79-9540). Connection to sockets 1.3 as indicated by the arrow.

2.1 Light exit. Dovetail ring mount for attachment to the microscope:

- Unscrew screw at 1.5 or 1.6 sufficiently.
- Attach dovetail ring mount of illuminator inclined in recess opposite the clamping screw, lower illuminator on to the seating surface and tighten the screw.

A holder in the light exit in front of the collector accepts a 42mm dia. heat-reflecting filter; the holder must be empty if the illuminator is used for UV blue fluorescence excitation.

2.2 Clamping screw to secure the lamp housing.

2.3 Focusing of lamp coil.

2.4 Vertical adjustment of lamp coil.

2.5 Horizontal adjustment of lamp coil.



2.6 Warning sign

Caution: Hot surface!

Let it cool down before you touch it!

Adjustment of halogen lamp with reflector

The exchange of the lamp is described on page 30.

- Remove illuminator Hal from microscope.
- Switch on halogen lamp from power supply.
- Use screw 2.3 to project sharp coil image on a wall or similar object approx. 3m away.
- Use screw 2.4 for vertical adjustment of the coil image and 2.5 for horizontal adjustment. Move the coil image in such a way that the gaps of the reflector image are covered (see Fig. 5). The fixed reflector need not be adjusted, since it lies exactly in the optical axis.

Fine adjustment:

- Remove internal tube with diffusing screen 1.5 and filter, if used, from light path. Attach microscope illuminator and focus on specimen using a 40x or higher-power objective. Look for a free object area.
- When the eyepiece is removed or the Bertrand lens slider 6.12 (see page 16) inserted in the tube, check whether coil image and reflector image are centered. If not, correct with the above-mentioned centering screws.
- Replace tube 1.5. Check homogeneous illumination of the pupil image and correct it, if required, with screw 2.3.

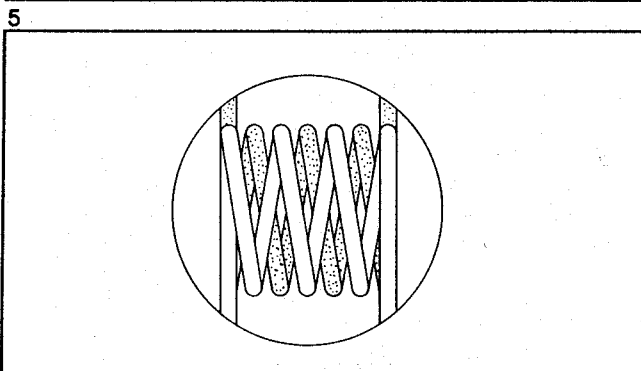
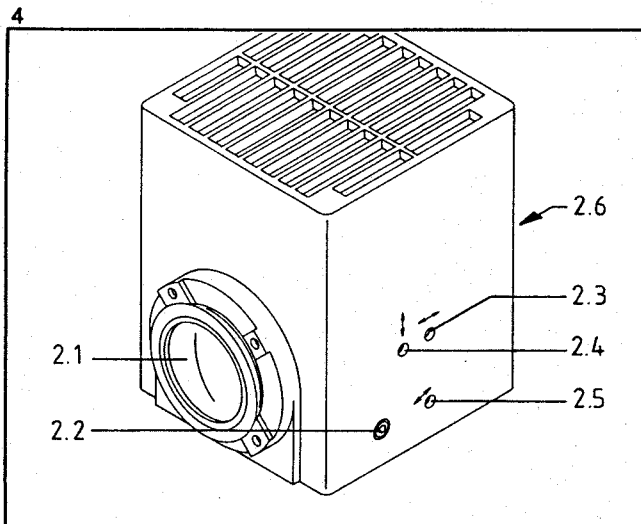

Note: For exchange of the 12V 100W halogen lamp see G 42-216 "Microscope illuminator Hal".

For the technical data of the halogen lamp see page 31 of these instructions.

You will need the HBO/XBO lamp housing with HBO 50 mercury lamp for incident-light fluorescence; it is described on page 20.

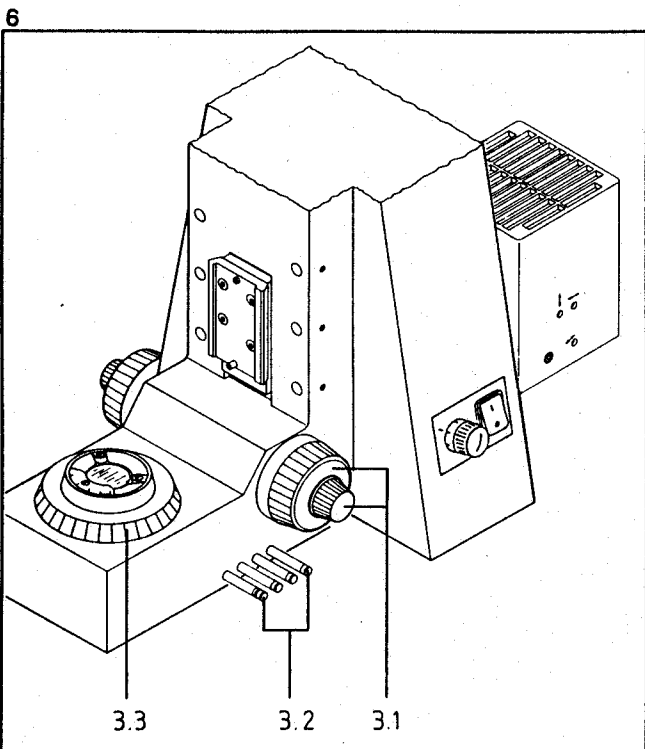

3.0 Stand base

The coaxial coarse/fine focusing controls **3.1** act on an oblong dovetail mount to which the stage carrier (with condenser carrier in transmitted light) is attached. The stage is lowered when the outer knob is turned towards the user. Total travelling range (including fine focusing control): 25mm.

- Coarse focusing control: one revolution corresponds to approx. 2mm travel; gear ratio of fine focusing control: 1:10. Index line of coarse focusing control can be used for rough measurement of the object thickness: 1 interval corresponds to approx 2 μ m.

3.2 Filter magazine in illuminating beam path with four pushbuttons, from front to back:

- dark-gray ring: 32mm dia. neutral density filter 0.06
- light-gray ring: neutral density filter 0.25
- green ring: green interference filter
- blue ring: conversion filter 3200/5500 K

The brightness is variable in steps using the neutral density filters singly or in sets. The transmittance of a filter set is determined by multiplication (e.g. $0.06 \times 0.25 = 0.015$, i.e. 1.5% transmittance).

The green interference filter increases the contrast in B/W photography.

The conversion filter converts artificial light of 3200 K into daylight of 5500 K.

If several filters are to be used at a time, the corresponding pushbuttons must be pressed simultaneously. Pressing the foremost button removes all filters from the beam path.

Exchange of filters in the magazine should be made by the maintenance service. (The bottom plate is removed. A filter - secured by a retaining ring - is accessible if all others are swung in).

The luminous field diaphragm **3.3** is adjusted by a knurled ring. The (removable) dust cover glass accepts a 32mm dia. filter. This plane is not imaged.

4.0 Specimen stage

Standard equipment is

- 4.1** mechanical stage 75x50/240°R (45 35 02-9903) with controls to the rear right, and
- 4.2** specimen holder with spring clip R (45 35 33) for exchangeable standard specimen slides (26x76mm); or, alternatively
- Mechanical stage 75x50/240°L (45 35 01-9903) with controls to the rear left and specimen holder with spring clip L (45 35 34).

The travelling range of the stage is 75mm in the X direction. In the Y direction it is factory-adjusted to 28mm (expandable to 50mm, see page 9). The maximum rotation is 240°.

4.3 Coaxial coarse/fine focusing controls to move the specimen in X and Y.

4.4 Graduations and verniers to relocate specific specimen areas.

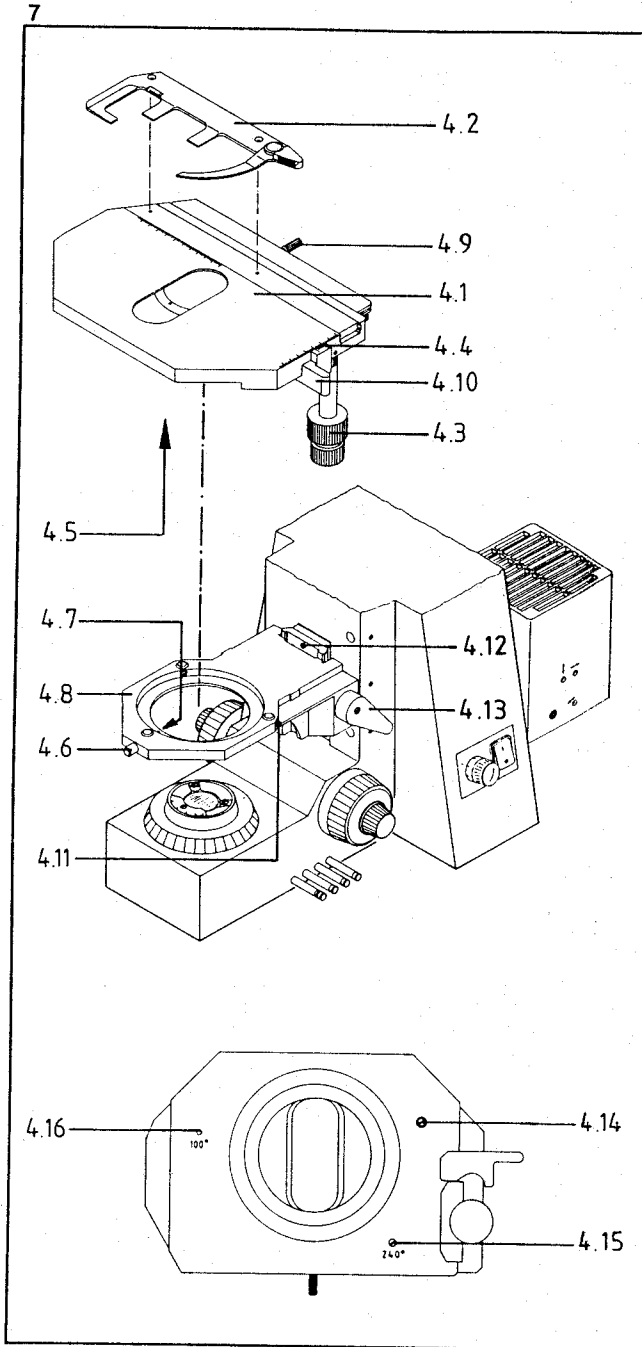

To mount the stage carrier on the oblong dovetail mount see page 25.

Insert specimen stage in specimen carrier 4.8 :

- Unscrew cap 4.6 approx. 3 - 4mm.
- Turn mechanical stage so that the coaxial controls 4.3 are at rear, see picture.
- Plug spring bolt 4.7 into notch of dovetail ring mount at 4.5 , press bolt down, insert dovetail ring mount of stage all the way in the holder and tighten the screw cap.
- Move up stage carrier with stage in oblong dovetail mount. Flick up clamping lever 4.13 , move stage carrier as far as upper stop 4.12 and secure it.

Loosen screw 4.9 by hand or with Allen key SW 1.5: you can now turn the mechanical stage with handle 4.10 , which prevents the specimen from being shifted by mistake. By turning the stage you can align an object within the photographic format or optimize the contrast in DIC.

Stage centration means that an adjusted specimen feature will remain in the center of the image and not migrate when the stage is turned.

If re-centration is necessary, proceed as follows:

Loosen screw cap 4.6 ; plug supplied small Allen screwdriver into 4.11 and correct migration during stage rotation until centration is re-established. Tighten screw cap 4.6 .

To extend the travelling range of the mechanical stage in the Y direction to 50mm, proceed as follows:

- Flick up lever 4.13 and remove stage and stage carrier from the microscope (see also page 25).
- Remove stop screw 4.14 in the white circle at the stage bottom.
- Remove stop screw 4.15 from "240°" and screw it into thread "100°" at 4.16 . This limits the stage rotation to 100° and prevents the stage from hitting the stand during rotation.
- Attach the specimen stage to the oblong dovetail mount, move the stage carrier to the upper stop 4.12 and secure.

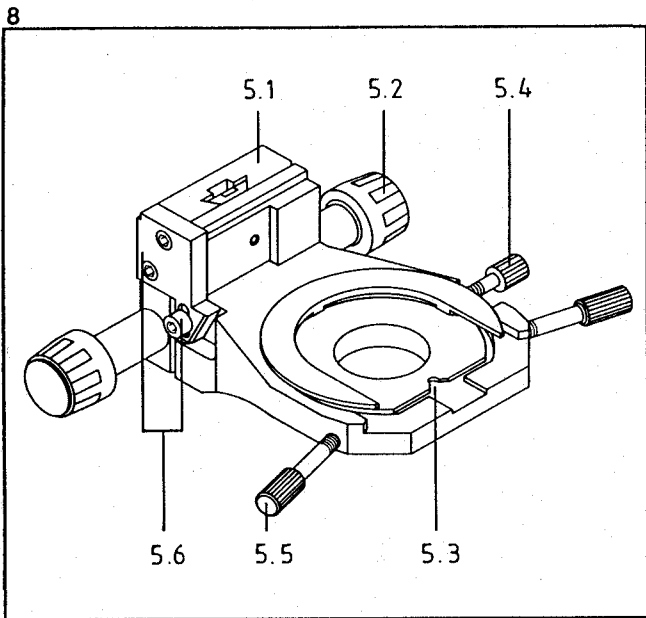

5.8 Front lens, aperture 0.6 or 0.9.

When exchanging the front lens, exchange also labels **5.17** designating the aperture on turret **5.16**.

5.9 Lever (on both sides) to swing the front lens in or out (for objectives 2.5x and 5x).

5.10 Knurled ring for aperture iris diaphragm, and, below, aperture scale of

5.11 brightfield insert (44 53 64) with

5.12 locking screw. When it is loosened and raised, the brightfield insert can be removed.

Illumination of large object fields with objectives 2.5x and 5x:
Without imaging of the luminous field diaphragm (Köhler illumination),

5.13 diffusing screen can be plugged on the front lens (pointing to the left). If the front lens is swung out and the diffusing screen swung in, you need not lower the condenser. The aperture diaphragm should be fully open, which is of advantage for routine work requiring quick change between low-power and detail investigations.

5.14 Automatic swivelling achromatic-aplanatic condenser system (44 53 51) corresponds to **5.7**, but the front lens is swung out automatically when lowering the condenser. It is swung in automatically when the condenser is lowered further, and remains in its position while moving up.

5.15 Achromatic-aplanatic condenser system (44 53 53) for highest illumination aperture 1.4. Its front lens (44 53 57) should always be connected with the bottom of the specimen slide by immersion oil. The front lens cannot be swung out, but may be unscrewed to illuminate the fields of 2.5x, 5x and 10x objectives; the aperture will then be 0.24. The condenser is suitable either for brightfield or for brightfield and DIC microscopy.

5.16 Condenser turret with 5 apertures, described on page 12. For insertion, guide the notch of the turret to the orientation screw, and exert light pressure to the rear and downwards to screw in the knurled screw.

5.0 Condensers

5.1 Condenser carrier including:

5.2 Controls on both sides for max. 34mm vertical adjustment. The stiffness is factory-adjusted and should be changed only by the maintenance service.

5.3 Orientation notch for condenser.

5.4 Clamping screw for condenser (used only for condenser exchange).

5.5 Two centering screws to center the luminous field diaphragm image for illumination adjustment (see page 5).

To prevent the specimen from being pressed out by mistake, the vertical condenser movement is limited by stop screw

5.6 which is adjusted as follows:

1. Adjust specimen (use a thick specimen slide).
2. Image the luminous field diaphragm (see page 5).
3. Move the condenser up by a small amount (diaphragm image becomes unsharp).
4. Loosen stop screw **5.6** with Allen key - the stop pin will fall down - tighten it again. Now the specimen is protected from being touched by the condenser.

The available condenser systems meet the high demands on the versatility of a large research microscope.

Standard condenser is

5.7 swivelling condenser system (44 53 50).

9

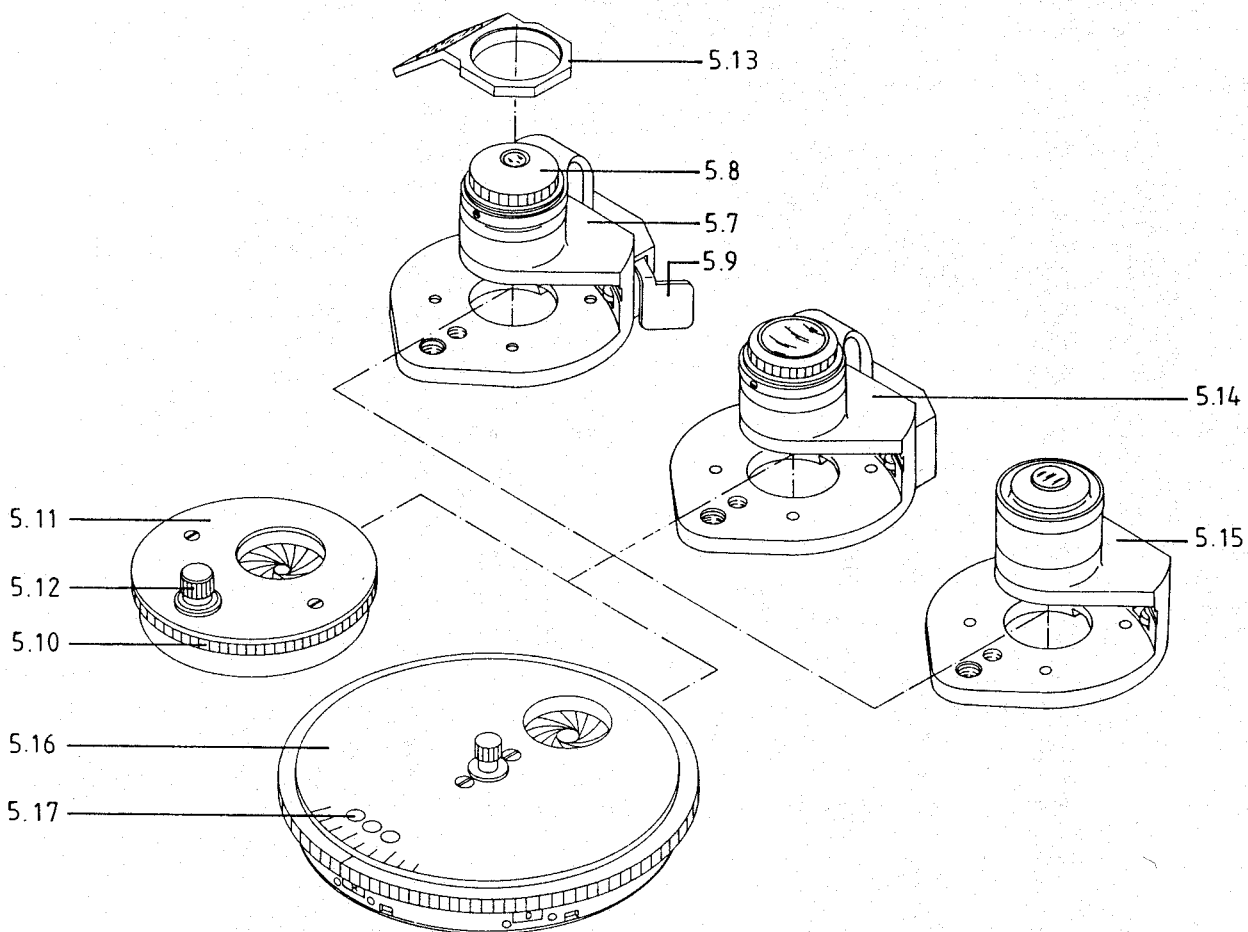

10

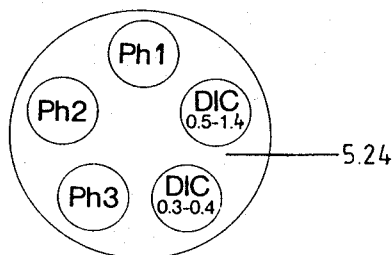
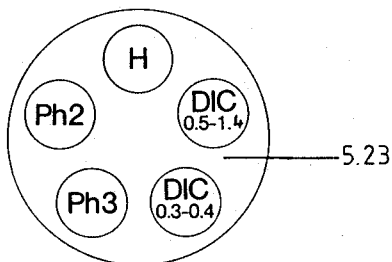
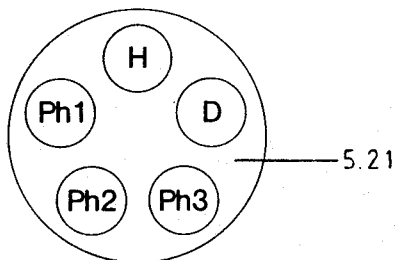
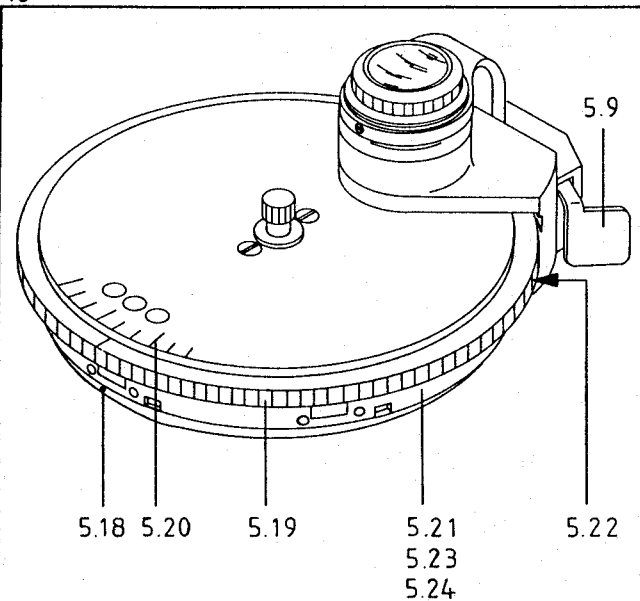

5.18 Index displaying the 5 apertures of the condenser turret, allowing quick change between different illumination and contrast-enhancement techniques.

5.19 operates the aperture diaphragm and

5.20 displays the aperture.

5.21 Condenser turret H D Ph (44 53 66), usually provided for

- brightfield (H)
- phase contrast 1 (Ph 1)
- phase contrast 2 (Ph 2)
- phase contrast 3 (Ph 3)
- darkfield (D)

The phase stops and darkfield diaphragms are centered using the two supplied keys through

5.22 centering openings. (The condenser system 44 53 50 has these openings before the right and behind the left lever **5.9**, with swung-in front lens.)

5.23 Condenser turret H D Ph DIC (44 53 65)

with standard equipment for:

- brightfield (H)
- 2 phase stops, as required: Ph 1, Ph 2 or Ph 3
- DIC 0.3 - 0.4
- DIC 0.5 - 1.4

The operating controls are like **5.21**.

5.24 Turret Ph DIC (44 53 67) with three centerable apertures, equipped with phase stops Ph 1, Ph 2, Ph 3, and two positions equipped with iris diaphragms for the corresponding prisms DIC 0.3 - 0.4 and DIC 0.5 - 1.4. Brightfield is produced in both DIC positions if the analyzer or the polarizer is removed from the beam path (see page 24).

Concerning DIC: Optical components with ordering numbers or aperture values in red are ideal for DIC, since they are virtually strain-free (Pol equipment).

11

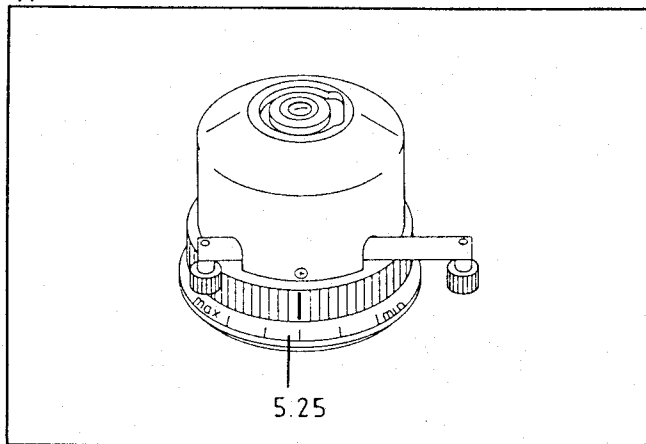

12

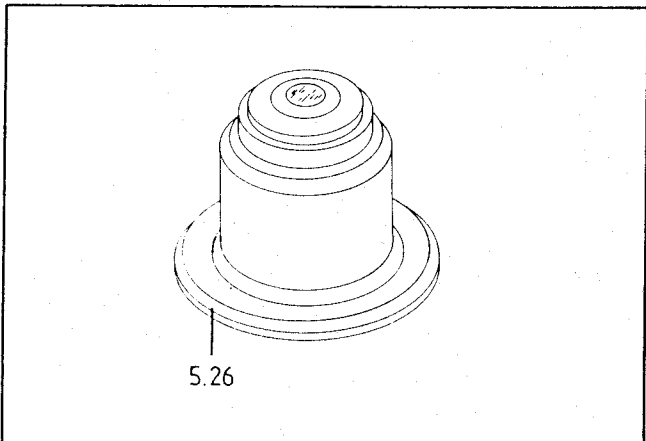

13

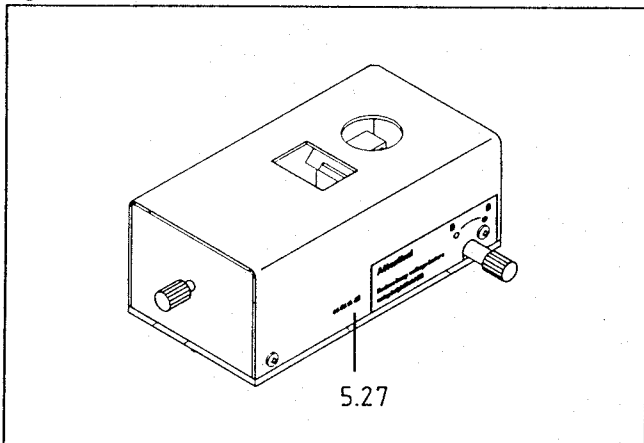

5.25 Achromatic-aplanatic switch condenser 0.5/20mm dia. (44 53 40)

- Brightfield condenser for 1.25x to 40x objectives
- Numerical aperture 0.5 with swung-in front lens
- Diameter of maximum illuminated field: 20mm
- Homogeneous illumination of field of view of 1.25x to 5x objectives with swung-out front lens and open aperture diaphragm.
- Köhler illumination for 5x to 40x objectives with swung-in front lens.
- Ideal for large specimens, e.g. in pathology.

5.26 Ultra darkfield condenser 1.2/1.4 oil (44 53 15) for maximum apertures in darkfield. The objective aperture should be lower than 1.2; stopping down with the objective iris diaphragm should be possible.

5.27 Darkfield illuminator for low magnifications from 2.5x to 10x, described on page 23.

Optical condenser data

Without front lens (swung out or unscrewed), all condensers have

- numerical aperture 0.24
 - 23mm working distance
 - luminous field of max. 11mm dia.
- and are suitable for
- 2.5x . . . 10x objectives.

The values in the table below apply to condensers with front lens:

N.A.	Working distance	Object field	for objectives
0.6	6.8mm	4mm dia.	10x . . . 100x
0.9	0.8 mm	2.8mm dia.	10x . . . 100x
oil 1.4 (air 0.9)	0.4mm	1.9mm dia.	20x . . . 100x

With 10x objective and in critical illumination, the exit pupil of the objective and the field of view can be optimally illuminated by focusing with 2.3 and centering with 2.4 and 2.5.

As an alternative you may work without front lens, however, at the expense of a slight loss in aperture.

For the equipment of the condenser with various diaphragms (phase contrast, etc.) see the table on page 28.

6.0 Image-forming components

6.1 Objectives, the most important elements of a microscope, must be kept meticulously clean, especially the front lens surfaces.

The numbers and figures engraved on the objectives, e.g.

Plan-Neofluar 20x/0.50; ∞ /0.17 signify:

20x (individual) magnification

0.50 numerical aperture (NA)

∞ image distance

0.17 computed for 0.17mm cover glass thickness

(Individual) magnification multiplied by eyepiece magnification (generally 10x) results in the microscope magnification.

The numerical aperture multiplied by 1000 (500 in the above example) is the highest useful magnification; no more details will be revealed above this value. The numerical aperture is important in darkfield illumination for the choice of the darkfield diaphragms.

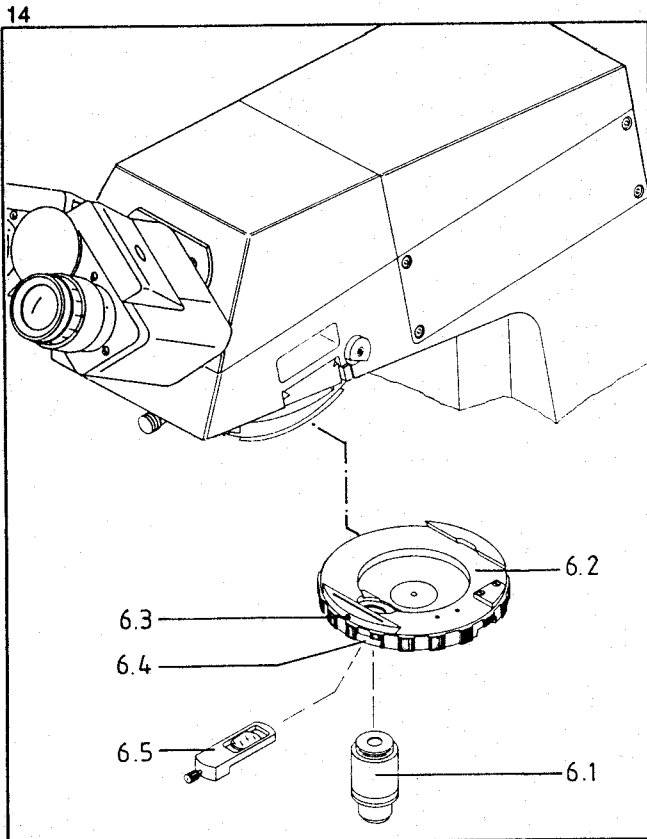

The symbol ∞ is to remind the user that these objectives cannot be used on microscopes with objectives bearing the number 160.

The cover glass thickness 0.17mm for transmitted-light specimens must be the more observed the higher the numerical aperture of the objective. Certain objectives can therefore be adjusted to different cover glass thicknesses (correction mounts). Find out, by means of a high-contrast specimen feature, in which position of the correction mount optimum sharpness is achieved (refocusing will always be necessary).

Immersion objectives are insensitive to differences in the cover glass thickness.

20x and higher-power objectives have resilient mounts to protect the specimen. To prevent specimens from being contaminated by oil if the nosepiece with immersion objectives is turned, the objectives can be locked in the upper position by turning the spring mount to the right (don't forget to disengage them from "lock-in" position).

The air between the cover glass and an immersion objective is replaced by a liquid, generally immersion oil. Some experience is required to achieve a bubble-free layer. Some microscopists prefer to turn the objective from the side into the oil drop on the cover glass, others recommend to lower the objective from "lock-in" position of the spring mount.

Constant checking of the exit pupil, preferably using Bertrand lens **6.12** or by taking out the eyepiece (as described on page 5) is recommended, since this procedure instantly reveals any bubbles. If the bubbles do not disappear even if the objective is swung in several times, clean the specimen and repeat the procedure.

6.2 Nosepiece. After loosening screw

6.3 it can be moved to the right and taken off (e.g. to check the front lens for cleanliness). (It cannot be detached if **6.17** is occupied.

If your microscope is equipped also for DIC, the knurled ring of the nosepiece 5x features

6.4 slots for

6.5 DIC sliders. They must snap in when inserted (designation face up). (See also DIC adjustment on page 23). Even if you are not working in DIC, you may leave the DIC sliders in their slots (dust protection!), provided the polarizer beneath the condenser is swung out.

The sliders for neutral density filters N 0.08, N 0.15, N 0.30 and N 0.50 can be inserted in slots **6.4**. This allows the compensation of brightness differences within one series of objectives, e.g. in TV microscopy or microflash photography (see table on page 31).

15

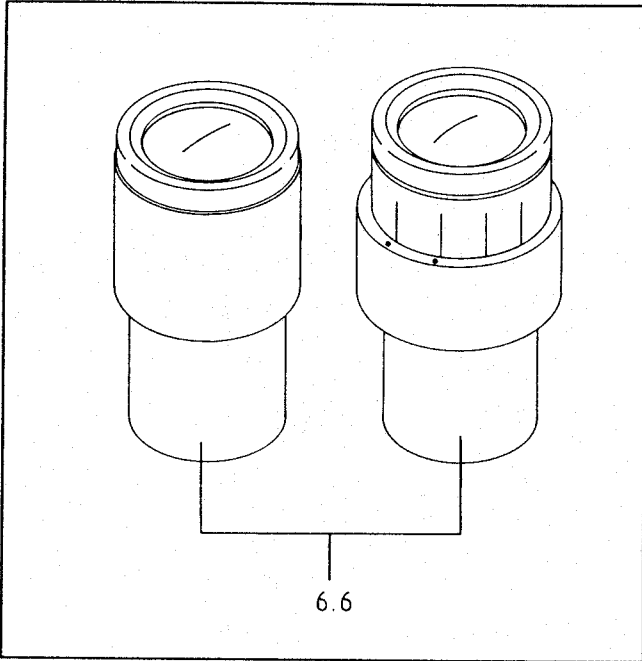

6.6 Eyepieces with 10x or 16x magnification and field-of-view number 25 or 16 produce angular fields of 54°, are ideal for eyeglass wearers (Br), and feature a removable ring of soft plastic to protect eyeglasses (folding eyecups 44 48 01 are also available). One eyepiece is a focusing eyepiece (foc); if your eyes have different powers or for microscopy without eyeglasses, make adjustment as follows:

- Look through the eyepiece and focus on the specimen with the less emmetropic eye.
- Leave this microscope adjustment unchanged. For the more emmetropic eye, focus through the eyelens of the focusing eyepiece until the specimen is in focus for both eyes. This eyepiece adjustment is facilitated by a screw which engages a notch in the eyepiece tube and thus secures the eyepiece position, which is important for the use of reticles.

Eyeglass wearers who take their eyeglasses off for microscopy may experience unsatisfactory objective parfocalization. Eyeglasses with a cylinder power must be kept on for microscopic work.

16

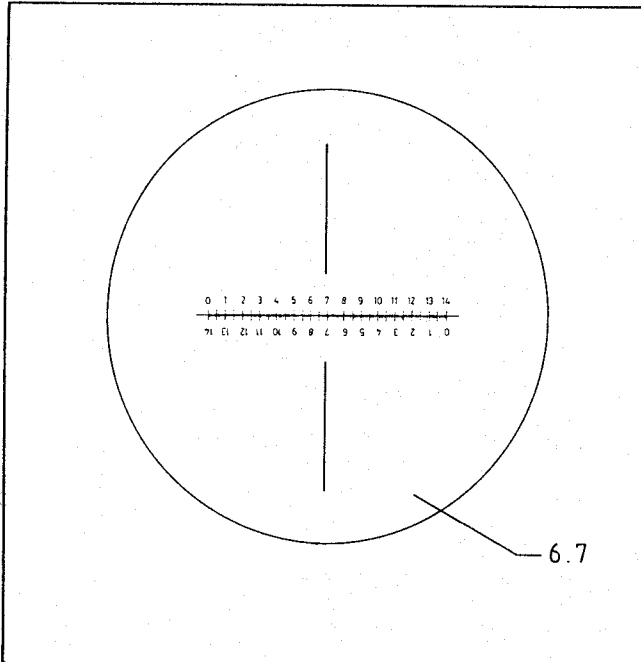

6.7 Reticles in the eyepiece diaphragm plane are used for measurement and to outline the photographic format of an attached microscope camera. They fit only in focusing (foc) eyepieces. The slight displacement of the image they cause is considered by the zero position on the diopter scale indicated by a red instead of a white dot.

Exchange of reticles should be left to specialists because of the high demands on cleanliness and exact alignment. (The lower part of the eyepiece can be unscrewed; the scale-bearing surface of the reticle must face down).

2 foc eyepieces are required for the use of a reticle. To focus a specimen, proceed as follows:

- Assign the eyepiece with reticle to the less emmetropic eye.
- Turn the ring on the reticle bearing eyepiece until the reticle is in focus.
- Focus the specimen in the reticle bearing eyepiece with the coarse/fine focusing control.
- Leave the microscope drive unchanged, and, with the ring of the other eyepiece, readjust the focus for the more emmetropic eye, until the object image is in focus for both eyes.

6.8 Optovar slider D (45 19 90) with the factors 1x (middle), 1.25x and 1.6x, for quick magnification change fits into

6.9 if spring pin

6.10 was pulled out, which provides for the stops at either end and prevents the Optovar slider from being pulled out by mistake.

The adjusted magnification factor (1.25x or 1.6x) of the Optovar is displayed on the top surface of the handle, next to the slider port.

6.11 Slot for

6.12 Bertrand lens slider (45 36 70) for convenient observation of the objective pupil, especially for phase-contrast diaphragm centering. Loosen screw

6.13 visible on the front of the stand so far that the slider can be inserted, and tighten it so far that it moves smoothly between the stops. The Bertrand lens, which is focused with a lever, is brought into the beam path when the slider is moved to the left.

Accessories for DIC

For brightfield/phase contrast microscopy, slot **6.11** accepts the Bertrand lens slider **6.12** and for DIC the analyzer

6.14 (45 36 55) or a slider with

6.15 analyzer with lambda plate (45 36 56). White symbols ensure correct orientation of both components.

For fast change between Bertrand lens (Ph) and analyzer (DIC), we offer both in a set: **6.12** (45 36 70) and

6.16 (45 36 65); the analyzer in the Bertrand lens slider can be swung in and out to the left, offering:

- free aperture (sliders pulled out to the left and right)
- analyzer in beam path (left slider pushed in)
- pupil observation (right slider pushed in)

6.17 Slot for auxiliary objects and compensators.

17

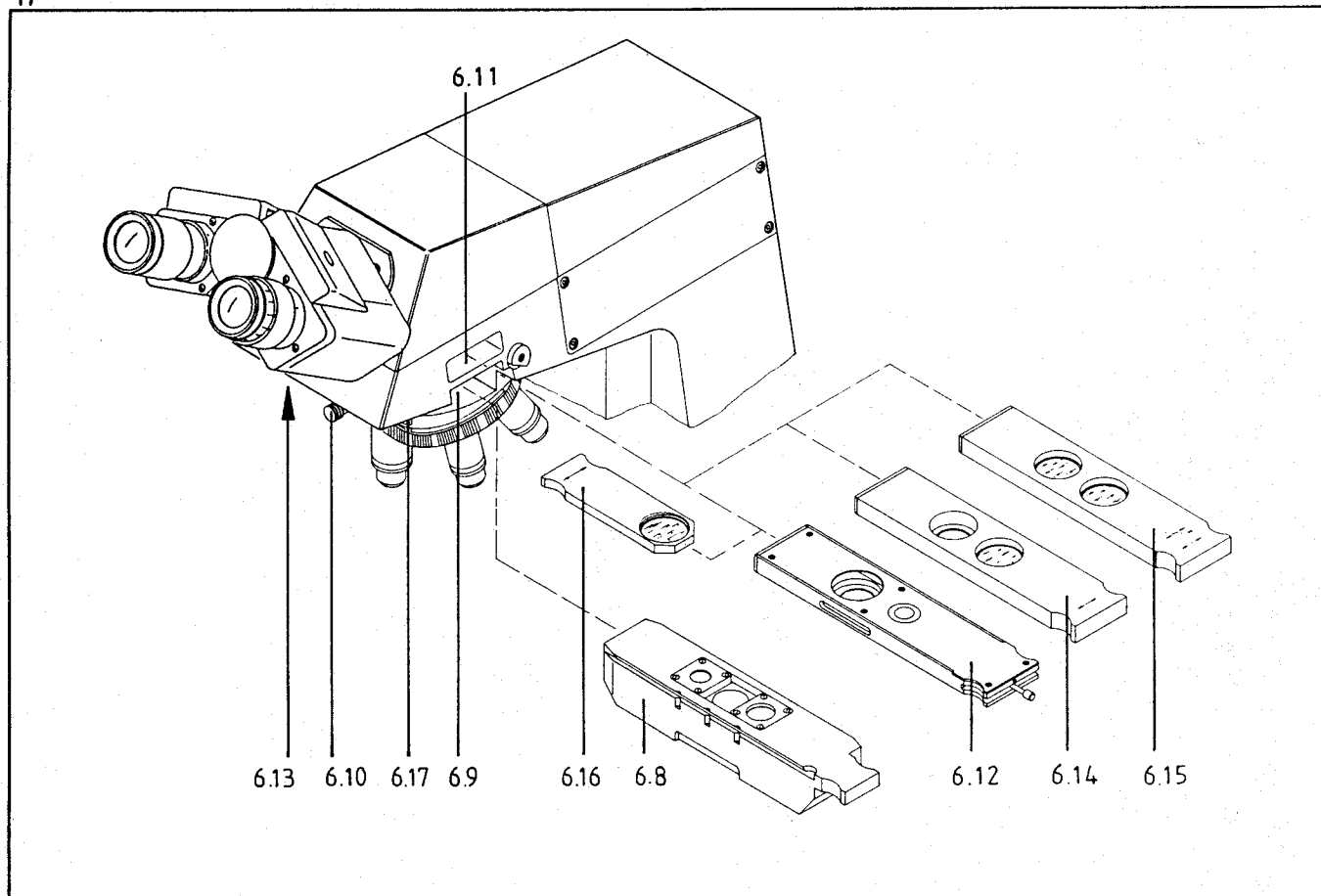

Any of the following tubes can be used on the Axioplan microscope:

6.18 Binocular tube 30°/25 Pol (45 29 16)

6.19 Binocular phototube 30°/25 (45 29 20)

Both have a viewing angle of 30° and a tube factor of 1x; PD adjustable between 55 . . . 75mm by turning the tube halves in or out; changing the PD does not affect the orientation of a reticle in either tube.

The binocular phototube 30°/25 features pushrod **6.20** on the right side, with the following click-stop positions: 100% of the light for observation (pushrod pushed in), or 20% of the light for observation and 80% to the camera (pushrod pulled out).

The phototube features a pushrod also on the left side, to operate the integral eyepiece shutter. The shutter is automatically open when in switch position "observation". It can be swung in or out in position "camera" (see **6.23**).

Binocular phototube (45 29 23) with sliding prism (not shown)

and pushrod with 2 click-stop positions:

pushed in: 100% of the light for observation

pulled out: 100% of the light to camera.

It is similar to tube **6.19**.

6.21 Vertically adjustable binocular phototube 25 (45 29 30)

The tube differs from the aforesaid by the viewing angle which is continuously variable between 5° and 30° by pushing the knob on the right side, which changes the viewing height by approx. 80mm. The image is upright and unreversed. The tube factor is 1.1x.

Panel V (45 18 81) is required for this tube.

To use the phototube on an intermediate tube (see page 26), unscrew the glass plate in mount from the bottom of the tube, and screw in adapter optics (45 29 64).

6.22 Binocular phototube with 2 ports (45 29 25)

It features two ports for cameras. The switching mirror directs the available light either to the upper or to the rear port. In addition to a microscope camera, a TV camera can be mounted on top/at rear.

A microscope camera or a TV camera can be mounted on the top tube port of the binocular phototube. Required are:

Adapter 45 29 96 for MC 100 and MC 80 microscope cameras; Adapter 1x (45 29 95) or 0.63x (45 29 97) for TV camera with C mount;

Adapter 1x (45 29 94) for TV camera 3C CTV with ENG bayonet mount.

For details see the operating instructions of the cameras.

18

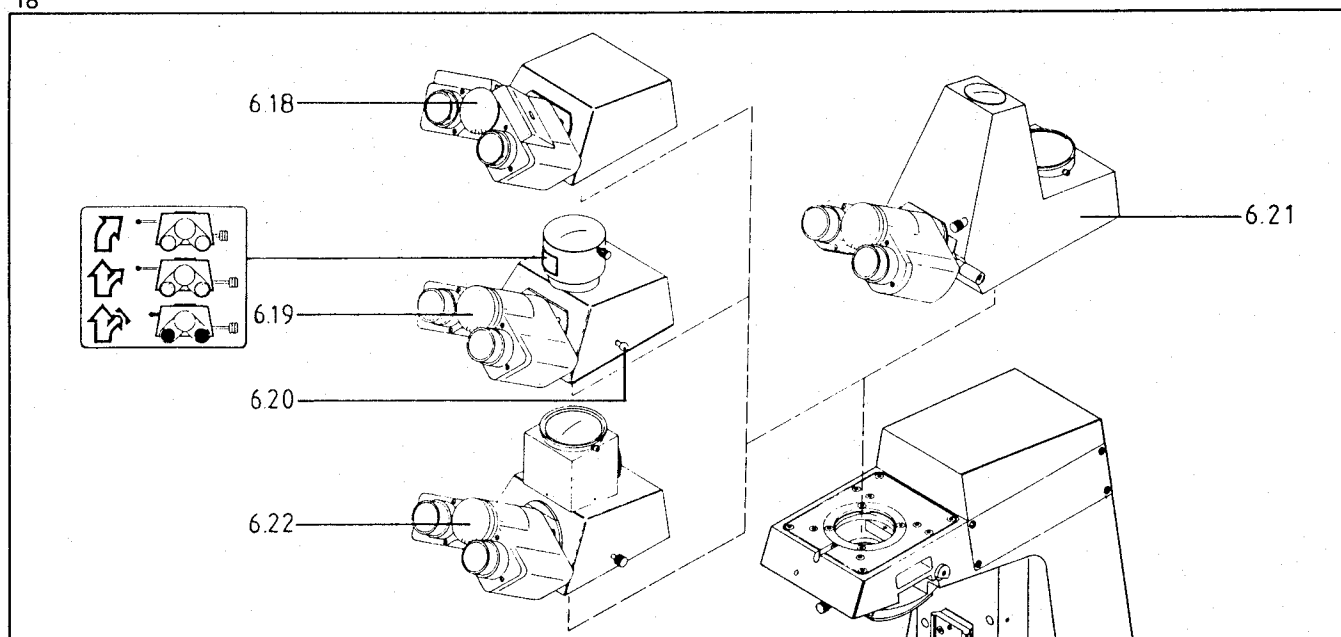

7.0 Fluorescence equipment

For fluorescence microscopy the instrument is equipped with reflected-light system FI (44 64 60).

Further components are:

7.1 Fluorescence illuminator with collector and HBO 50W mercury lamp supplied from a separate power supply 39 26 42.

7.2 Three slots for sliders on the side of the microscope. The rearmost is generally used for a slider which either interrupts the illumination beam path (fully inserted), brings a red-attenuating filter BG 38 into the beam path, which eliminates disturbing IR light (middle position), or provides free aperture. The other two slots are for accommodation of filter slider A with one 18mm dia. aperture for an additional exciter filter. A heat-reflecting filter KG 1, which does not affect UV excitation, is invisible from the outside.

7.3 Lever for luminous field diaphragm.

7.4 Centering screws for luminous field diaphragm.

7.5 Reflector slider 3 FI fits like Optovar magnification changer **6.8** in transmitted-light brightfield and, like **6.8**, has three apertures: the one in the middle is free for brightfield or phase contrast observation, the others accept suitable exciter filter/chromatic beam splitter/barrier filter sets (see also page 30).

Stick-on labels in fields I, II and III on the top surface of the reflector slider display the built-in filter sets.

For further details see page 29. If your microscope is retrofitted for fluorescence microscopy, the reflector slider 3 FI will be supplied with two

7.6 sheet-metal covers which protect the fluorescence filters from dust; these covers must be inserted in the analyzer slot.

Barrier-filter slider 45 19 81 accepts additional 25mm dia. barrier filters for specific fluorescence methods. It is inserted in slot **6.11**.

19

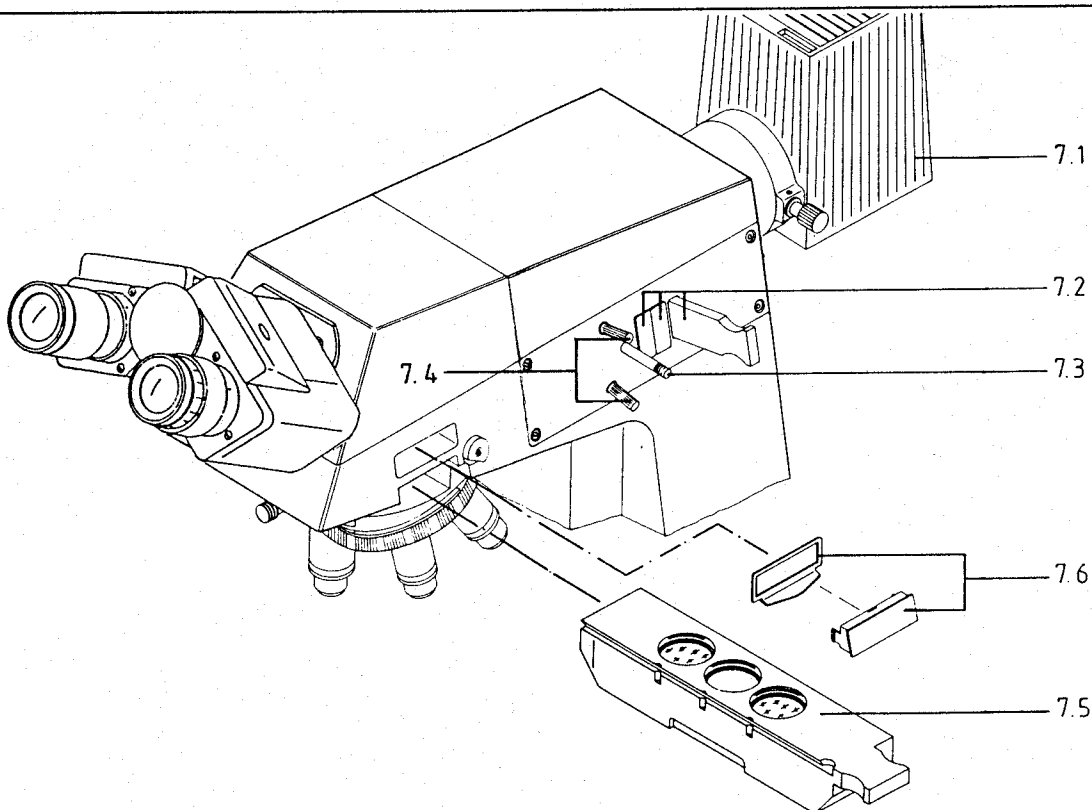

Required equipment

- No special objectives, but Plan-Neofluar objectives for UV excitation.
- Special reflected-light illuminator 7.1 , described on page 20.

Procedure

- Adjust the selected specimen feature in transmitted-light brightfield or phase contrast using reflector slider 7.5 in middle position (free light path) and lower illuminator with halogen lamp. Switch on the HBO 50 mercury lamp, but block its light path with rear slider 7.2 .
- Switch off transmitted-light illuminator (or reduce at least its brightness), remove all filters in magazine in the stand base from the beam path, select the left or right position of the reflector slider, depending on the type of excitation, and remove slider 7.2 from the beam path.
- Since a narrowed aperture diaphragm would reduce brightness in reflected-light fluorescence, only a luminous field diaphragm is provided. Use lever 7.3 to close it so far that it becomes visible in the image. Then center with 7.4 and open the diaphragm until the field of view is free.

Special notes

Use a 20x objective and a strongly fluorescent specimen for the first fluorescence adjustment. Suitable specimens can be supplied, but you can also prepare them yourself; a specimen of spread anthracene crystals is quite popular. (A specimen label can be used to check the illumination).

The reflector slider contains several filter sets for different tasks. Each set comprises one exciter filter, one barrier filter (25mm dia.) and a chromatic beam splitter (26x26mm) in between. For more information on the various components please see page 30.

20

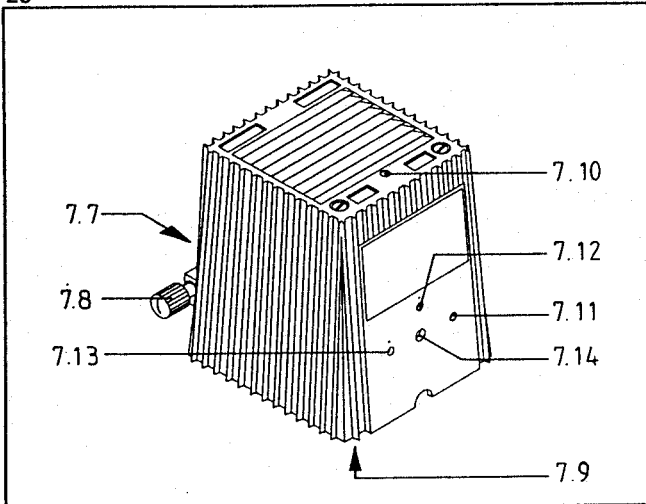

21

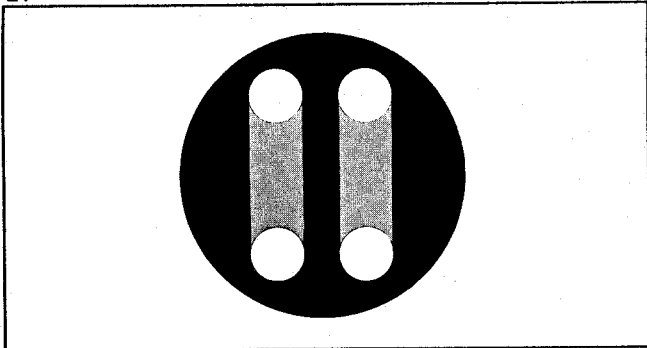

Fluorescence illuminator

The exchange of the HBO 50W mercury lamp is described in operating instructions G 42-160. The HBO/XBO lamp housing has the following features:

7.7 Light exit with dovetail ring mount for attachment of the illuminator to the microscope. Loosen screw for attachment of illuminator by a few turns.

Insert dovetail ring of illuminator in the mount opposite the clamping screw, then lower illuminator on to the contact surface and tighten the screw.

7.8 Knob for collector adjustment.

7.9 Clamping screw for lamp socket (concealed at the bottom of the housing).

7.10 Vertical lamp adjustment.

7.11 Lateral lamp adjustment.

7.12 Vertical adjustment of reflector image.

7.13 Lateral adjustment of reflector image.

7.14 Focusing of reflector image.

To center the HBO 50, proceed as follows:

- With screwdriver SW 3 remove switched-on illuminator carefully from the microscope.
- Use knob **7.8** for collector adjustment to image the brighter of the two light arc images in focus on a wall approx. 3m away. To prevent damage to the eye by UV radiation, avoid looking into the light spot of the ignited lamp for too long.
- With screwdriver SW 3 set the light arc image to the center using screws **7.10** and **7.11**.
- Focus the light spot with adjusting screw **7.14**; lamp image and reflector image should have the same size. Then use screws **7.12** and **7.13** (marked red) to adjust the reflector image and the real image side by side (see Fig. 27). The two images must not overlap.
- Attach illuminator again and tighten clamping screw **1.6**. Open slider at **7.2** and set reflector slider to blue excitation (e.g. filter set 48 79 09 for FITC fluorescence).
- Unscrew objective and check the image of the light source on a sheet of paper placed approx. 20mm below the empty aperture of the nosepiece.
- Make corrections with knob **7.8** and screws **7.10** to **7.14**. Screw in objective again.

The HBO 50W mercury lamp must be exchanged after expiration of the mean lifetime of 100hrs. Its illuminance decreases in the course of many hours of use so that homogeneous illumination of the object field can no longer be guaranteed. There is also danger of explosion. The remaining lifetime can be read off on the power supply unit.

Special note

For more details and specially the important safety provisions and technical data of the lamp we refer to the manual G 42-160 Microscope lamp HBO 50 for fluorescence

It is applied mainly to increase the contrast of unstained specimens.

Required equipment

- Objectives (1) designated Ph. They may be used in brightfield as well.
- A condenser (5) with turret (2) with Ph positions.

Additional adjustment

The phase rings in the objectives are of different size, and marked Ph 1, Ph 2 and Ph 3 on objective (1). Turret (2) bears the same designations - Ph 1, etc. - for combination with the suitable objective. Condenser turrets with 2 or 3 Ph positions are available (5.21, 5.23 or 5.24).

Perfect phase contrast is achieved only if the dark ring in the objective and the bright ring in the condenser exactly coincide; this is controlled with swung-in Bertrand lens (6) and focusing with lever (7) to the right. (Without Bertrand lens, control is made like that of the condenser diaphragm, described on page 5).

If the two rings do not exactly coincide (coincidence of the two rings should be as to the right in Fig. 25), correct with the centering screws which are accessible through openings (4); see also 5.22.

The centration is maintained when the condenser turret is turned or exchanged. To enhance the contrast, a green filter is brought into the beam path either in magazine 3.2, or inserted in color filter carrier or on luminous field diaphragm 3.3.

Special notes

More than in brightfield, meticulously clean glass-to-air surfaces of the specimen (fingerprints!) are necessary in phase contrast. The diaphragm ring (3) of the condenser is without function, since the Ph apertures do not contain iris diaphragms. The diaphragms in the Ph apertures of the condenser are part of the front lens of a specific condenser; they must be exchanged if the front lens is exchanged (see table on page 28).

22

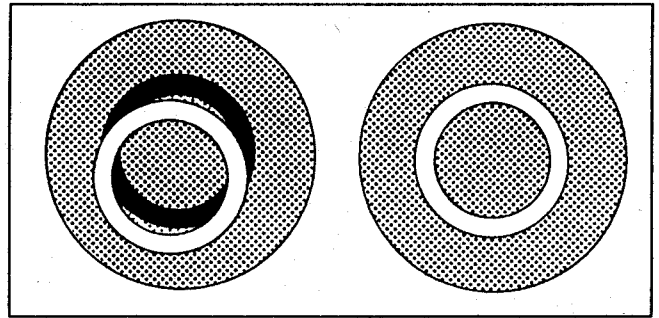

23

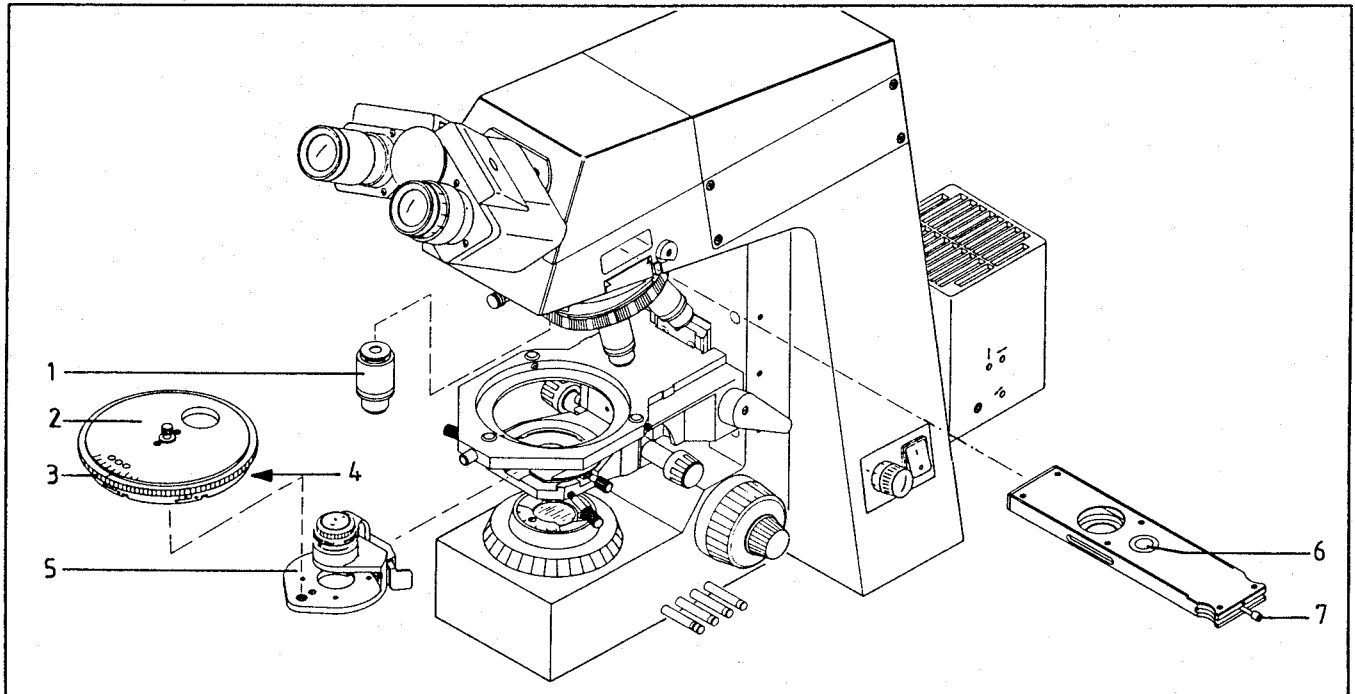

It is applied

- to examine exceptionally small objects or object features, such as treponemas, spirochaetae, flagella, bacteria, etc., or emulsions, if the phase contrast is insufficient;
- if the specific colors of natural, i.e. unstained, objects (living organisms in water, like algae, unicellular organisms, lower animals) are well visible.

Required equipment

- Special objectives with integral iris diaphragm only at high magnification, but
 - always a condenser with central stop and a numerical aperture which is higher than that of the objective in use (see table on page 13).
- For details see the opposite table.

Necessary adjustments

- Illumination adjustment as in brightfield; imaging and centration of the luminous field diaphragm are possible and necessary. If the condenser height is correctly adjusted, there will be an approximately sharp image of the luminous field diaphragm.
 - Check the objective pupil for perfect extinction.
- With ultra condenser 5.26 there will sometimes remain a luminous ring in the pupil; it disappears when you operate the iris diaphragm of the objective. The background of the eyepiece image must be absolutely black, a criterion which is influenced also by the position of the luminous field diaphragm, especially at the edge of the field of view.

Special notes

Darkfield requires cleaner specimens than other methods; especially grease films (fingerprints) will lighten the background.

The critical adjustment of the ultra darkfield condenser is facilitated by precentering with a low-power objective. Use a specimen with uniform feature distribution, e.g. blood smear, for initial adjustment; the luminous field becomes visible only where particles light up, but the darkfield specimen ultimately examined may be "blank" over wide areas.

Darkfield illumination with selected objectives

<u>Plan-Neofluar</u>	<u>Plan-Apochromat</u>	Illumination:
10/0.30	10/0.32	Ph stop ≥ 0.44
20/0.50 40/0.75	20/0.60	darkfield stop 0.76 - 0.90
100/1.3 oil iris	40/1.0 oil iris 100/1.3 oil iris	ultra darkfield condenser 1.2 - 1.4 oil

**Darkfield illuminator (2) 44 53 14 - 9901
for low magnifications between 2.5x and 10x**

Warning: When changing between darkfield and brightfield always reduce the lamp brightness to prevent dazzling.

Optimization of darkfield illumination

- Slide illuminator (2) into condenser carrier; screw (4) of the dovetail ring mount must engage notch (1). Secure with screw (8).
- Switch to darkfield position (symbol) using screw (5).
- With condenser drive move illuminator just beneath the stage carrier.
- Turn in 1.25x objective.
- Load auxiliary object (diffusing paper strip) and focus.
- Close luminous field diaphragm (6). With screw (3) produce uniform vignetting at upper and lower edge of field of view. This changes the tilt of the spherical mirror. Establish right/left symmetry of condenser carrier using two centering screws (7) of the condenser carrier. The remaining vignetting at top and bottom of the field of view is unavoidable, but the photographic field is homogeneously illuminated.
- Load specimen; large specimen slides and cover glasses are most suitable, because diffusing edges are far outside the object field.
- If the brightness of the image is too high, remove the diffusing screen from the illuminating light path. Opening luminous field diaphragm (6) will provide for more light on the specimen, but also for more reflections outside the photographic field.
- When changing to the next higher objective magnification 2.5x, vary mirror tilt with screw (3) until reflex-free illumination of the field of view is obtained. Adjust the luminous field diaphragm until the darkness of the image background is optimized. At objective magnifications up to 20x the adjustment of the luminous field is adequate without changing the mirror position.

24

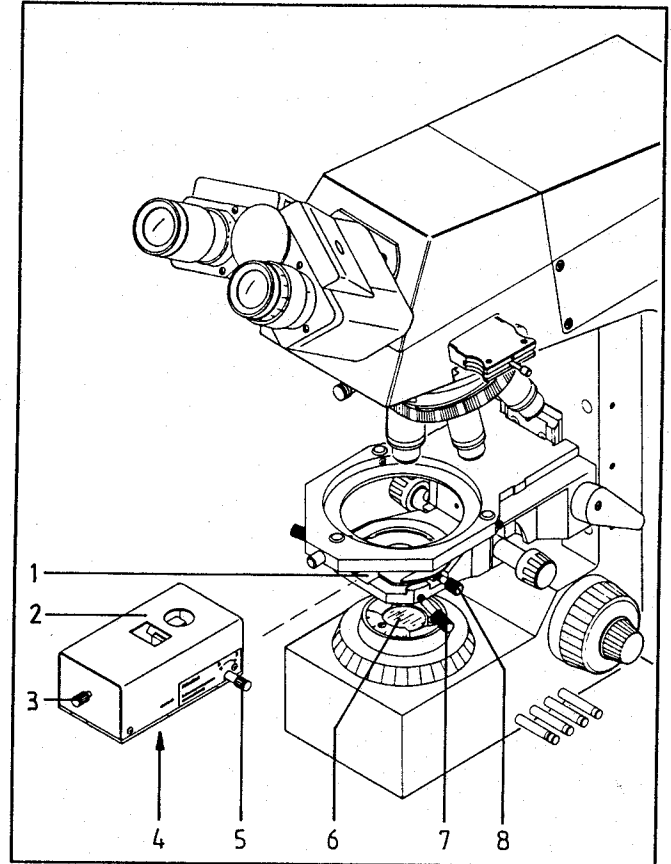

It is applied, for instance, if a specimen is too thick for phase-contrast examination so that specimen layers outside the focal plane impair the brilliance of the image, or if the halo which is typical of phase contrast interferes with the observation of small features.

Required equipment

- Normally Plan-Neofluar objectives.
- Special nosepiece (1) with slots (2) to accommodate
- DIC slider (3) bearing on its top surface magnification and aperture of the objective for which it is intended. Insert DIC slider in slot (2) until it snaps in.
- Condenser turret (4) with DIC positions.
- Polarizer (5) which is swung in beneath the condenser.
- Analyzer (10) which is slid into (8).

Additional adjustment

Similar to the 3 (or 2) Ph positions of the condenser there are 2 DIC positions, one for objective apertures 0.3 . . . 0.4, the other for apertures from 0.5 . . . 1.4.

This permits the following combinations:

- | | | |
|--|---|----------------------------------|
| <ul style="list-style-type: none"> ■ objective 10x/0.30 and condenser position DIC 0.3 - 0.4 ■ objective 20x/0.50 ■ objective 40x/0.75 ■ objective 100x/1.30 | } | condenser position DIC 0.5 - 1.4 |
|--|---|----------------------------------|

Unlike the Ph positions, the DIC positions are provided with iris diaphragms. Open them completely at first. To enhance the contrast, they can be slightly closed, which is generally the last step of the adjustment.

Optimum contrast is adjusted with the knurled screw of the DIC sliders (3) in the nosepiece.

Special notes

In DIC, contrast is generated by a (pseudo) relief and, in the case of linear structures, depends on the orientation of these structures: in "light-shadow" direction it will be low, but highest in a direction at right angles to this direction. Specimen rotation is, therefore, required for adjustment. You should, therefore, use the mechanical stage as rotary stage (see page 9).

To ensure reflex-free illumination, luminous field and aperture diaphragms should not be opened wider than for Köhler illumination (see page 5).

As DIC uses polarized light, "optically active elements" between polarizer and analyzer will interfere, e.g. mica plates which are sometimes used for histological sections, or plexiglass culture dishes with plastic bottoms (dishes with glass bottoms are available).

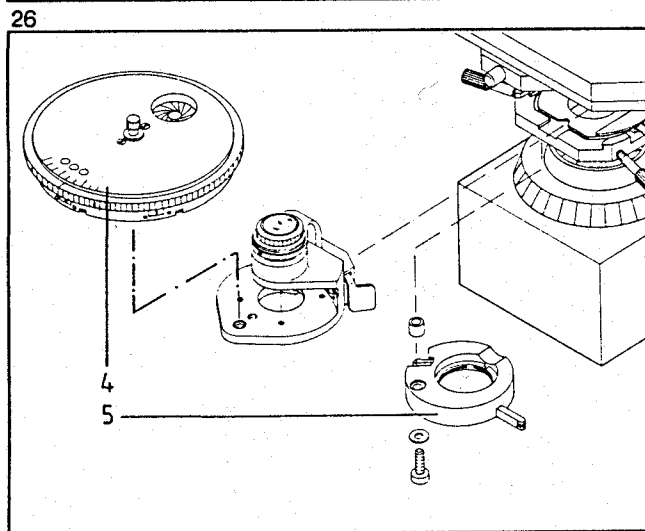
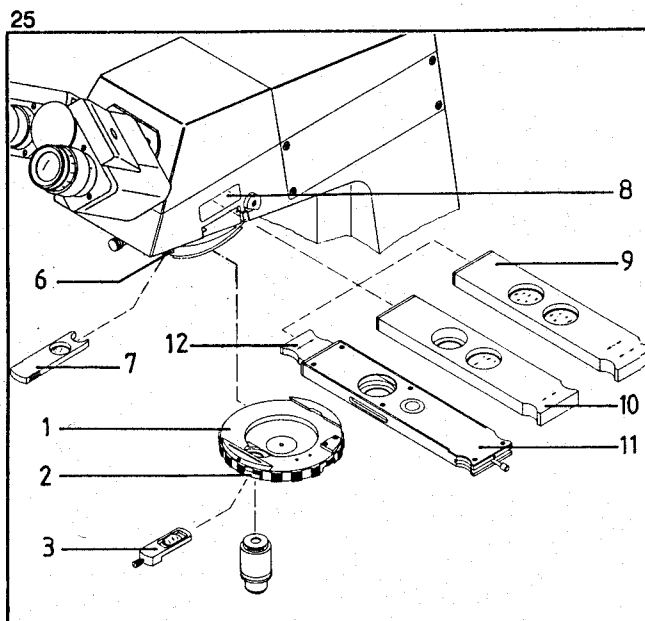

Analyzer with lambda plate (9) (45 36 56) instead of normal analyzer (10) (45 36 55) will generate color DIC. The same effect is achieved with auxiliary object lambda (7) (47 37 04) in slot (6). For combined DIC/phase contrast, use Bertrand lens slider (11) with analyzer (12).

The prisms in the DIC positions of the condenser are part of the front lens of a specific condenser; they must be exchanged when the front lens is exchanged (see table on page 28).

27

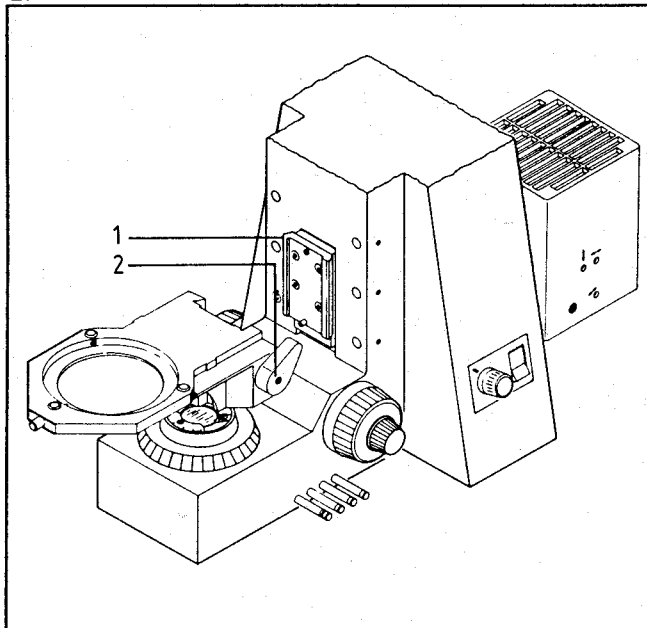

28

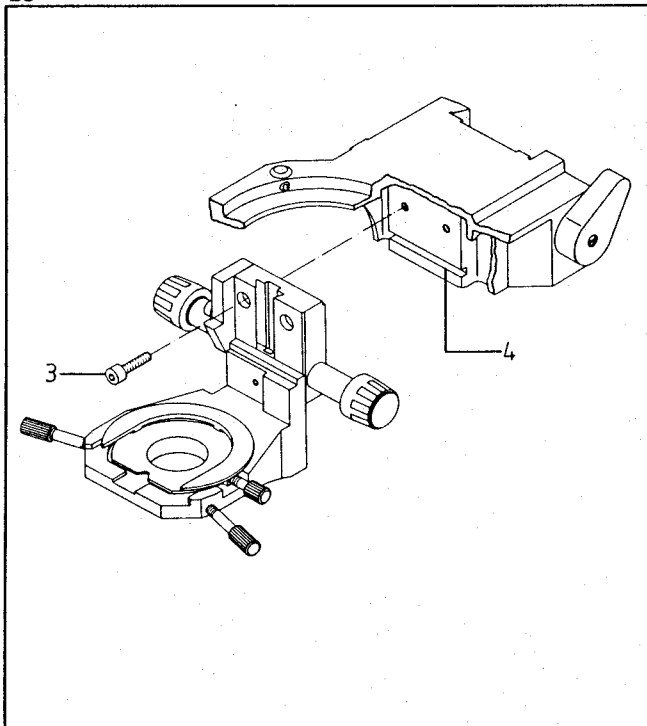

29

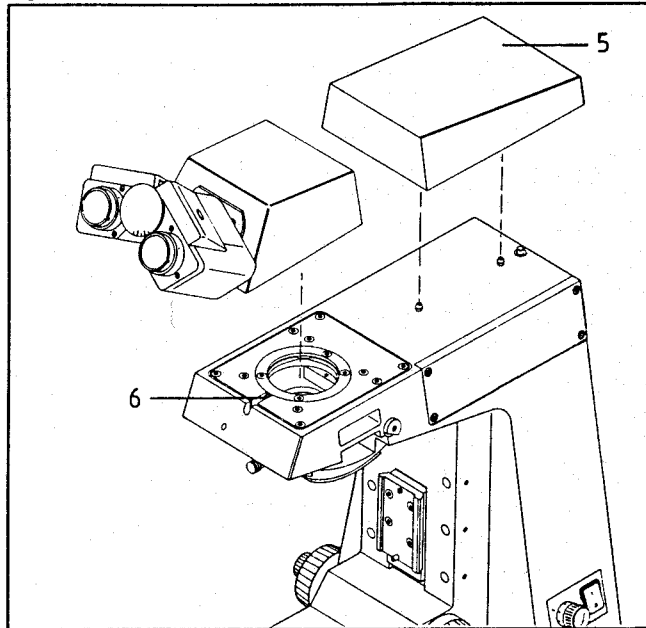

Should minor changes of your microscope be necessary and no service technician available, the following hints may be helpful.

Stage components

Detachment from mounting plate: flick up lever (2) (right) and turn off the entire unit about the left edge (1) of the plate.
Attachment: put stage carrier against top stop screw, attach it to the left edge and - lever up - press down right side. The spring pin is pressed down and fixed when the lever is flicked down. The condenser carrier (transmitted-light equipment) can be removed after loosening 2 screws (3) on the front. When remounting the carrier, make sure that the two orientation pins engage notch (4) and then tighten the screws.

Tube

To exchange the tube, proceed as follows: pull up tube panel (5). Loosen Allen screw (6) and take off the tube. (Unscrew the Allen screw so far that it is no longer visible when looking into the tube). Insert new tube, secure it with the screw and put on the tube panel.

Intermediate tubes

The following intermediate tubes can be attached to the Axioplan stand 45 18 10-9901.

Zoom intermediate tube 1x . . . 4x (45 19 02) (Fig. 35)

The zoom intermediate tube (3) continuously extends the magnification range of the microscope from 1x to 4x. The requested magnification can be set with knob (8) and the zoom factors read off the scale. A measuring scale with 1mm (1,000 μm) bar distance is integrated. This defined measuring distance is imaged on the film, if it is within the photo reticle.

The measuring scale can be inserted and positioned in the field of view using pushrod (2). Measuring scale and specimen are sharp at the same time.

The length of the imaged measuring distance is dependent only on the objective magnification; it is not influenced by additional magnifications. The distance between two bars is computed as follows:

$$1000/\text{objective magnification in } \mu\text{m},$$

i.e. 100 μm for the 10x objective.

Assembly

- Remove tube panel (6) and binocular tube (1) from microscope. Unscrew both pins (7) using a screwdriver and turn in clamping screw (5) until it is no longer visible.

- **Unscrew tube lens (4) from the binocular tube, otherwise you cannot use the microscope** by using cover of case 45 95 11; store tube lens in the case.

If the microscope is used without intermediate tube, the tube lens must be screwed into the binocular tube.

- Attach zoom intermediate tube (3) to the stand so that its dovetail is positioned securely on the tube mount. Screw in pins (7). Align the intermediate tube parallel to both stand edges.

- Push zoom intermediate tube to the back until thread (9) becomes visible in the stand.

- Insert screw loosely and both washers at (9) at the back of the stand.

- First tighten front clamping screw (5) and then rear screw at (9).

- Attach binocular tube (1) without tube lens to the intermediate tube and tighten clamping screw.

- Snap tube panel (6) on the two pins (7) of the zoom intermediate tube.

30

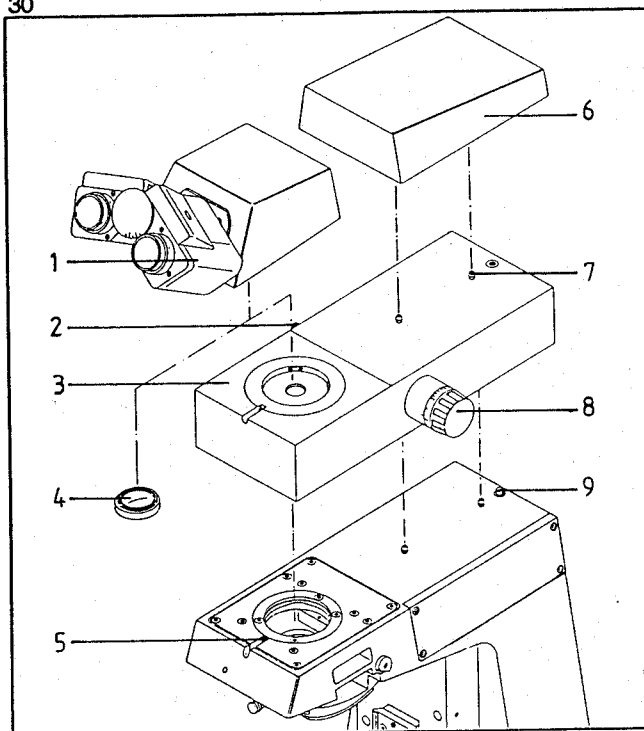

Co-observation bridge with light pointer (45 19 15)

See operating instructions G 42-404.

Axiophot microscope camera (45 19 37-9902)

See operating instructions G 42-410.

Intermediate tube with two TV ports (45 29 26)

See operating instructions G 42-211.

Intermediate tube for image projection (45 14 65)

See operating instructions G 42-403.

31

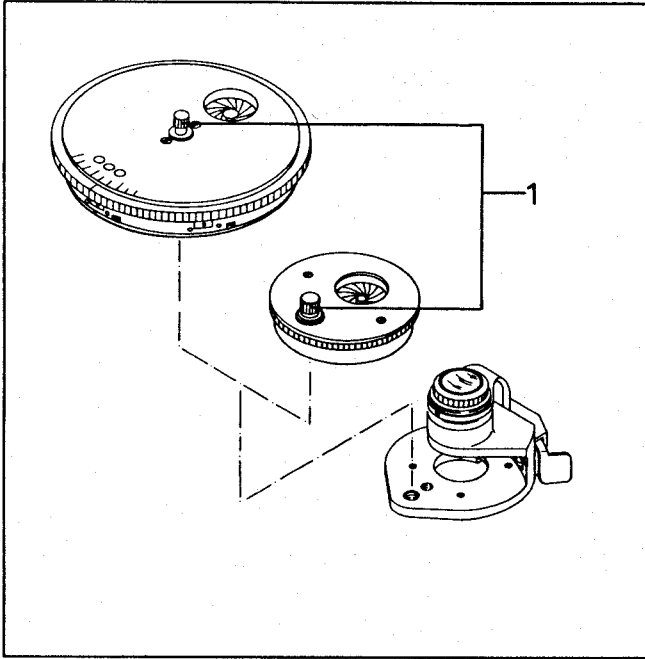

Condenser exchange

To convert a brightfield condenser into a phase contrast, DIC or darkfield condenser, only inserts must be exchanged, but not the entire condenser. For exchange, slacken and raise locking screws (1).

The entire condenser must be exchanged for an ultra darkfield condenser or the condenser system 1.4. The condenser must then be lowered as far as possible with (2). Slacken clamping screw (3) and pull out the condenser in a forward direction. The new condenser is inserted accordingly; notch (4) ensures correct insertion. A pin on the condenser carrier serves as lower stop and prevents the condenser from hitting the luminous field diaphragm insert.

32

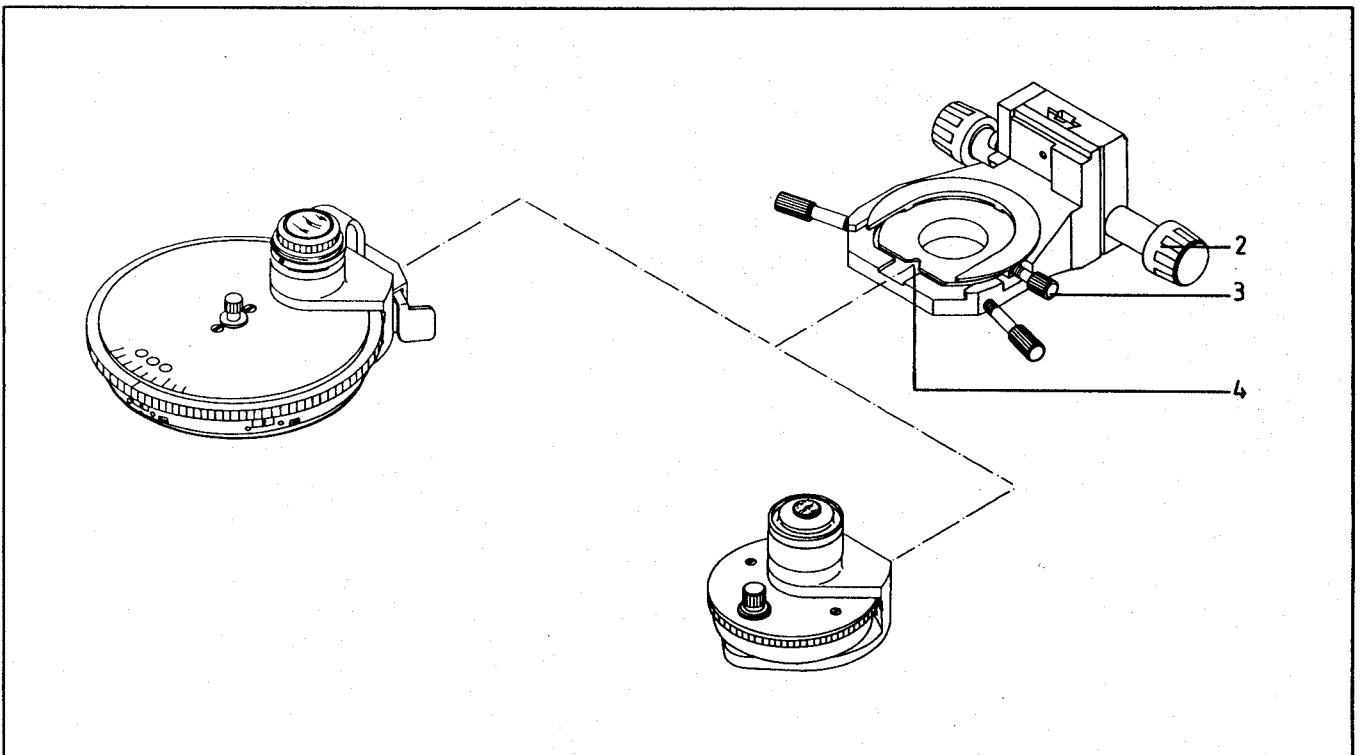

33

Exchanging phase stops and/or DIC prisms in condenser turrets

Fit phase stops only in centerable apertures and DIC prisms only in apertures with iris diaphragm. For further details see Fig. 33. The equipment of the condenser turret is listed in the table below.

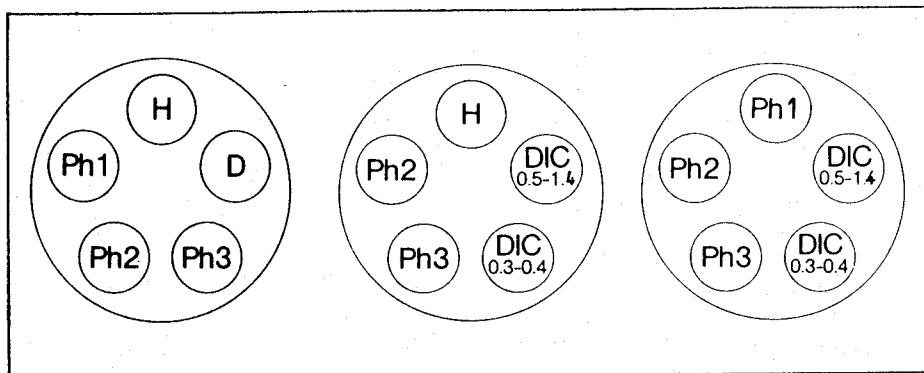

Possible equipment of the condenser system

Insert Turret	Mount for diaphragms, etc.	with front lens	Possible equipment
Brightfield insert (44 53 64)	1 plug mount with iris	0.6 (44 53 55)	brightfield
		0.9 (44 53 56)	brightfield DIC 0.3 - 0.4/0.9 (44 53 73) DIC 0.5 - 1.3/0.9 (44 53 74)
		1.4 (44 53 57)	brightfield DIC 0.5 - 1.4/1.4 (44 53 89)
Darkfield insert (44 53 63)	1 centerable mount	0.9	D 0.75 - 0.9 (44 53 99)
Turret H D Ph (44 53 66)	plug mount with iris	0.6	brightfield,
		0.9	brightfield, DIC 0.3 - 0.4/0.9 (44 53 73) DIC 0.5 - 1.4/0.9 (44 53 74)
	4 centerable mounts	Ph 1/0.9 (44 53 69)	Ph 2/0.9 (44 53 70) Ph 3/0.9 (44 53 71) Ph 3/1.4 (44 53 86) D 0.75 - 0.9 (44 53 99)
		1.4	brightfield, Ph 3/1.4 (44 53 86) DIC 0.5 - 1.4/1.4 (44 53 89)
Turret H D Ph DIC (44 53 65)	3 plug mounts with iris 2 centerable mounts	like turret H D Ph	like turret H D Ph
Turret H D Ph DIC (44 53 67)	2 plug mounts with iris 3 centerable mounts	like turret H D Ph	like turret H D Ph

34

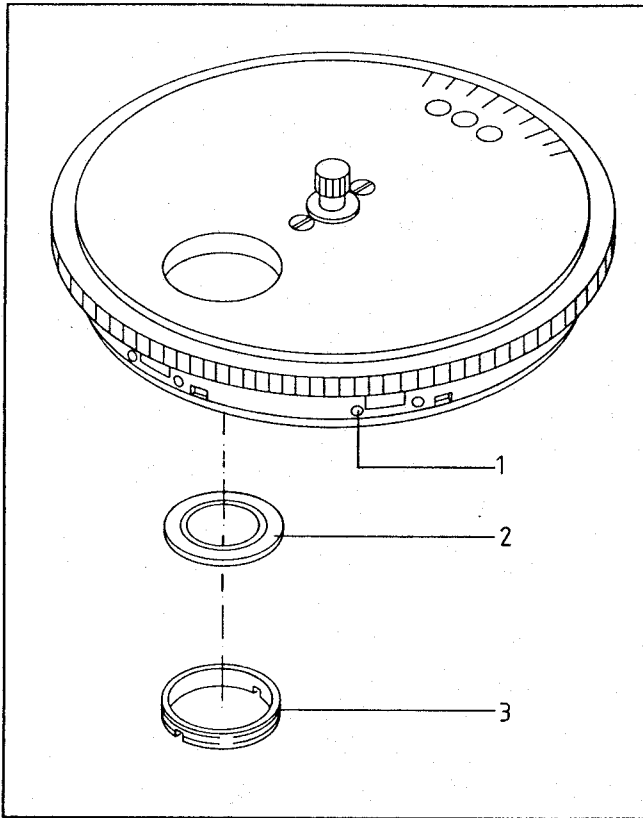

Phase stops or darkfield diaphragms are exchanged from beneath the turret. Unscrew retaining rings (3) with supplied key and insert diaphragms (2) with their polished glass surfaces facing down. If you cannot secure the diaphragms with the retaining rings due to movement of the diaphragm mounts, secure them with the centering screws at (1).

35

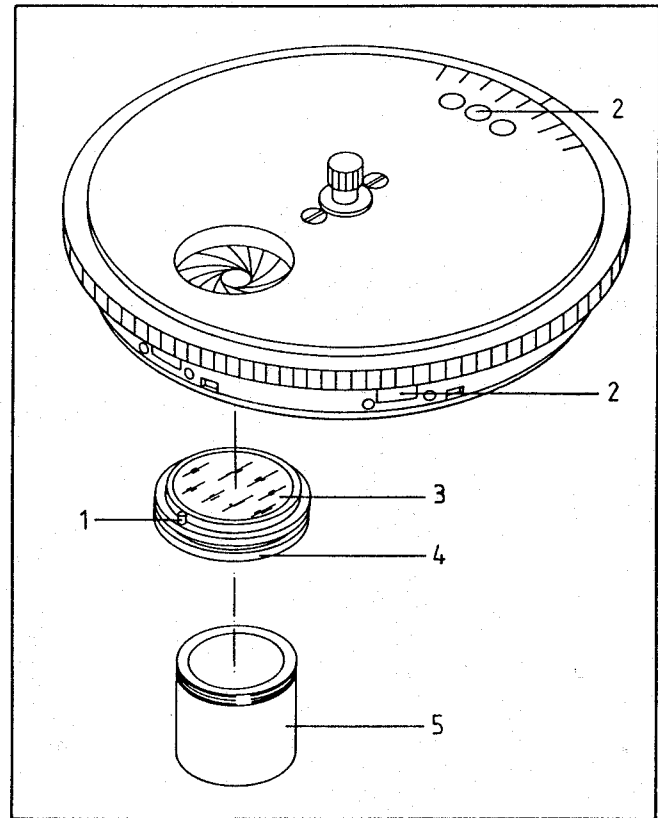

DIC prism exchange: screw tool (5) into prism mount (3) forming a handle to take the prism out. (A wire ring in the holder engages a notch (4) in the prism mount). Pin (1) must be in the correct borehole of the holder to enable insertion of the prism. Check for absolutely flat seating to prevent mechanical or optical malfunctions.

Insertion of the DIC prism in brightfield insert 5.1 is the same as in the condenser turret.

Special note: After diaphragm or prism exchange do not forget to also exchange the labels which are correctly fitted on the turret (2) opposite the corresponding aperture.

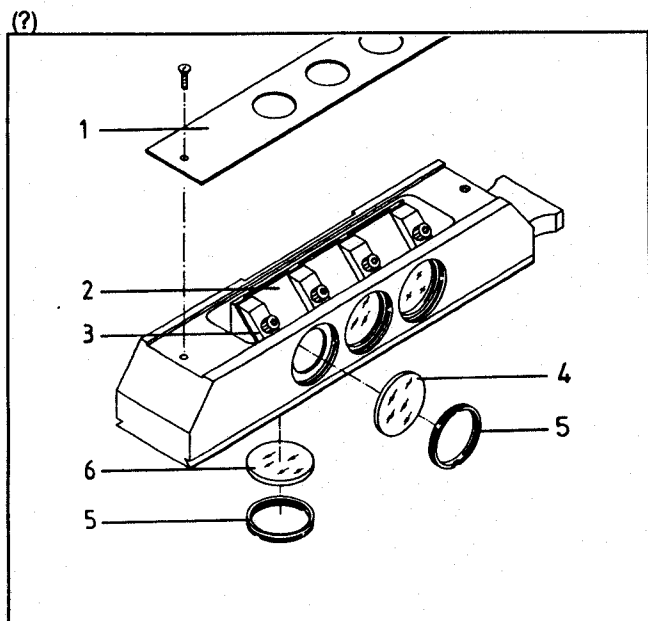

Fluorescence reflector

Exchange of exciter filter (4), barrier filter (6) and chromatic beam splitter (2). The integral filter sets can be exchanged after removal of retaining rings (5). Remove plate (1); the plate carrying chromatic beam splitters (2) is accessible. It is mounted on a spring mask and should not be touched. Generally, straps (3) need not be removed, but must only be slackeden to exchange the beam splitter on the mask.

When plate (1) is mounted it is not symmetrical; make sure that the free apertures are not cut off.

Fluorescence filter sets

Excitation	Filter set	Excitation filter	Chrom. beam splitter	Barrier filter
UV-G 365	48 79 02	G 365	FT 395	LP 420
UV-H 365	48 79 01	BP 365/12	FT 395	LP 397
Blue purple H 436	48 79 06	BP 436/10	FT 460	LP 470
Blue H 485	48 79 16	BP 485/20	FT 510	LP 520
Blue H 485 SB	48 79 17	BP 485/20	FT 510	BP 515-565
Green H 546	48 79 15	BP 546/12	FT 580	LP 590
UV purple 390-420	48 79 18	BP 390-420	FT 425	LP 540
Blue purple 395-440	48 79 05	BP 395-440	FT 460	LP 470
Blue 450-490	48 79 09	BP 450-490	FT 510	LP 520

Excitation	Filter set	Excitation filter	Chrom. beam splitter	Barrier filter
Blue 450-490 SB	48 79 10	BP 450-490	FT 510	BP 515-565
Green 510-560	48 79 14	LP 510-KP 560	FT 580	LP 590
Green 530-585	48 79 00	BP 530-585	FT 600	LP 615
Green H 546	48 79 20	BP 546/12	FT 560	BP 575-640
FURA-2 UV 340+380	48 79 21	BP 340/10* BP 380/10*	FT 395	BP 500-530
Red 575-625	48 79 26	BP 575-625	FT 645	BP 660-710
Blue + Green 485 + 546	48 79 23	BP 485/20 BP 546/12	FT 500 FT 560	BP 515-530 BP 580-630
Blue + Oran. 485 + 578	48 79 24	BP 485/20 BP 578/14	FT 500 FT 600	BP 515-540 LP 610

*18mm dia. filters

Parts which may need replacement are listed below with the numbers and in the order as they appear in the instrument description starting on page 6.

1.2 Spare fuses for

220 ... 240V: 2 A/H SB (INR 149.688)
100 ... 120V: 4 A/H SB(INR 149.691)

1.5 42mm dia. heat-reflecting filter 46 78 28; it is inserted so that the more reflecting surface faces the light source.

44mm dia. diffusing screen 45 18 51-0003, (use small screwdriver to loosen the retaining rings); they are inserted accordingly.

2.0 Use only 12V 100W halogen lamp

38 00 79-9540. Other commercially available lamps may cause trouble both optically and mechanically. Because of fingerprints do not handle the lamp with bare hands.

6.1 PCB-free immersion oil:

Plastic oiler containing 50 ccm immersion oil (46 29 58)

7.1 HBO 50W mercury lamp 38 16 19

7.2 18mm dia. red-attenuating filter BG 38 (46 79 91-9901)

Slider for neutral density filters to compensate the brightness of objective series

(for slotted nosepiece see page 24 (1)).

Neutral density filter slider N 0.08	44 44 90
Neutral density filter slider N 0.15	44 44 91
Neutral density filter slider N 0.30	44 44 92
Neutral density filter slider N 0.50	44 44 93

Condenser density	Plan-Neofluar	Neutral filter slider
Brightfield condenser 44 53 50 + 44 53 56	2.5x/0.075	N 0.08
	5x/0.15	N 0.08
	10x/0.30	N 0.08
	20x/0.50	N 0.15
	40x/0.75	N 0.15
	100x/1.30 Oil	-
Brightfield condenser 44 53 40	1.25x/0.035	N 0.15
	2.5x/0.075	N 0.15
	5x/0.15	N 0.15
	10x/0.30	N 0.15
	20x/0.50	N 0.30
	40x/0.75	-

Power supply of Axioplan microscope

Power supply switchable to 230V for	220 ... 240V AC
or to 115V for	100 ... 120V AC
Voltage tolerance	+ 10%
Line frequency	50 ... 60Hz
Power consumption	225VA

Socket 1.3 (page 7)

for 12V 100W microscope illuminator

Stabilized DC voltage:	3 ... 12V
suitable for photometry (unmodulated light)	

12V 100W halogen lamp	38 00 79-9540
Lamp voltage	12V
Power	100W
Color temperature at 11.5V	3200 K
Luminous flux	3100lm
Mean life	50hrs
Luminous surface	3.2 x 3.2mm ²

* For photography using artificial-light color reversal film sensitized for 3200 K, adjust halogen lamp to 11.5V with knob 1.7 .

Safety provisions

VDE-GS-, IEC 1010-1, CSA- and UL-tested.

The instrument is radio-screened and short-circuit-proof.

Environmental conditions

The instrument is for indoor use only.

Temperature range	min. 5 ... max. 40°
Relative humidity max.	80%
Avoid condensation water!	

Instrument specification

Protection class I
Contamination level 1 (IEC 1010-1)
Overvoltage class II

